



# CATALOGUE

## **NHÔM XÂY DỰNG CỬA HỆ S100-S130-S134**

*ALUMINIUM FOR BUILDING & CONSTRUCTION  
DOOR S100 - S130 - S134*

## MỤC LỤC CONTENTS

	Trang / Page
THƯ NGỎ / OPEN LETTER .....	1
CỬA SỔ BẬT HỆ 100 / CASEMENT WINDOW 100 .....	2-3
CỬA ĐI MỞ QUAY & VÁCH NGẮN HỆ 100 / SWING DOOR & PARTITION 100 .....	4-10
CỬA ĐI & CỬA SỔ LÙA HỆ 100 / SLIDING DOOR & WINDOW 100 .....	11-15
CỬA ĐI MỞ QUAY HỆ 130 / SWING DOOR 130 .....	16-18
CỬA ĐI MỞ QUAY HỆ 134 / SWING DOOR 134 .....	19-22



## THƯ NGỎ OPEN LETTER

Kính gửi Quý Khách hàng và đối tác,

Công ty TNHH Nhôm định hình Sapa Bến Thành (Sapa BTG) chân thành cảm ơn Quý khách hàng đã luôn tin tưởng và đồng hành cùng chúng tôi.

Được thành lập từ năm 1996, Sapa BTG có 30 năm kinh nghiệm trên thị trường, chuyên sản xuất và cung cấp sản phẩm nhôm định hình chất lượng cao, đáp ứng theo các tiêu chuẩn quốc tế (như JIS, ASTM, EN, AS/NZS, AA, ISO...).

Sản phẩm được sử dụng phôi nhôm chính phẩm, xử lý bề mặt cao cấp bằng công nghệ hiện đại và gia công cơ khí hoàn chỉnh, nên ứng dụng rộng rãi trong hầu hết các lĩnh vực, từ kiến trúc xây dựng, trang trí nội thất, gia dụng đến các ngành công nghiệp đòi hỏi kỹ thuật cao như cơ khí, điện, điện tử, vận tải, ô tô, đóng tàu, năng lượng (mặt trời và gió).

Quan điểm kinh doanh được xây dựng dựa trên mối quan hệ mật thiết với khách hàng và đặt chất lượng lên hàng đầu. Đây là nền tảng giúp Sapa BTG trở thành đối tác chiến lược và nhà cung cấp uy tín của nhiều doanh nghiệp lớn trong và ngoài nước. Chúng tôi tin rằng với năng lực và kinh nghiệm chuyên sâu, Sapa BTG sẽ giúp quý khách hàng tối ưu hóa chi phí thông qua những giải pháp kỹ thuật hợp lý.

Sapa BTG mong muốn trở thành đối tác chiến lược đồng hành và đóng góp vào sự phát triển bền vững của Quý khách hàng.

Trân trọng,

Sapa BTG.

Dear valued customers and partners,

Sapa Ben Thanh Extrusion Co., Ltd. (Sapa BTG) wishes to extend its sincere gratitude for your consistent trust and partnership.

Established in 1996, Sapa BTG now stands on three decades of proven experience in the market. We are dedicated to manufacturing and supplying the high-quality aluminium extrusion product, compliant to the international standards (including JIS, ASTM, EN, AS/NZS, AA, ISO, etc.).

Our products are extruded from the primary aluminum billet, featuring advanced surface treatment technologies and the meticulous mechanical machining. This ensures their wide application across diverse sectors: Architecture & Construction, Interior and External Furniture, and Household Goods, as well as highly demanding industrial fields such as Mechanical, Electrical, Electronics, Transportation, Automotive, Shipbuilding, and Renewable Energy (Solar and Wind).

Our business motto is based on close relationships with customers and the dedication to quality excellence. This foundation has established Sapa BTG as a strategic partner and trusted supplier to many leading companies, both locally and globally. We are confident that our in-depth expertise and operational capacity will assist you in achieving the cost-efficiency via practical engineering solutions.

Sapa BTG looks forward to serving as your trusted strategic partner, actively contributing to your success and sustainable growth for years to come.

Sincerely,

Sapa BTG.

**CỬA SỔ BẬT HỆ 100, ĐỘ DÀY TRUNG BÌNH 1.5 mm**  
**CASEMENT WINDOW 100, AVERAGE THICKNESS 1.5 mm**

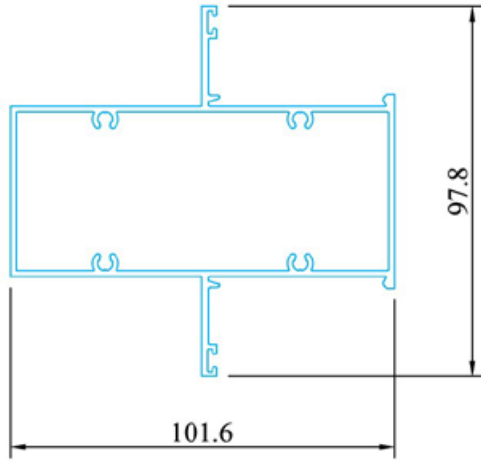

**3345**

W = 1.673 kg/m  
 T = 1.5 mm

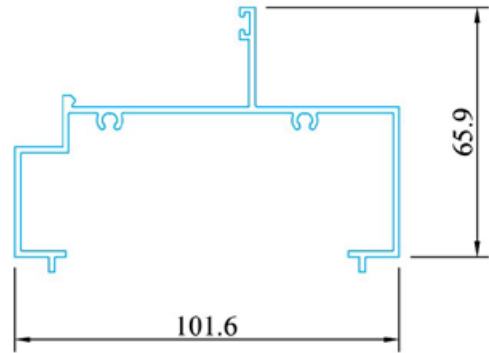

**3340**

W = 1.095 kg/m  
 T = 1.5 mm

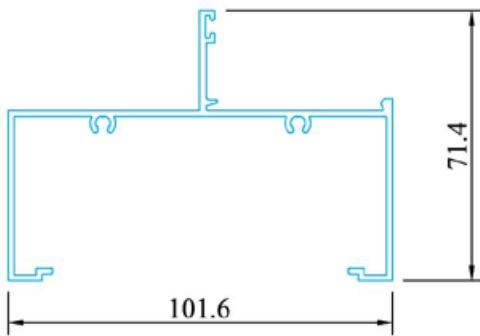

**3344**

W = 1.115 kg/m  
 T = 1.5 mm

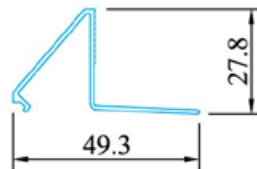

**3342**

W = 0.279 kg/m  
 T = 1.1 mm

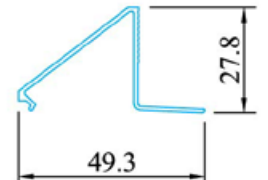

**3343**

W = 0.260 kg/m  
 T = 1.0 mm

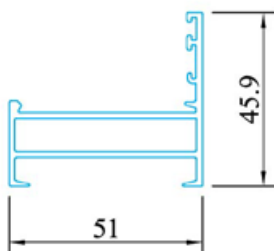

**5373**

W = 0.757 kg/m  
 T = 1.5 mm

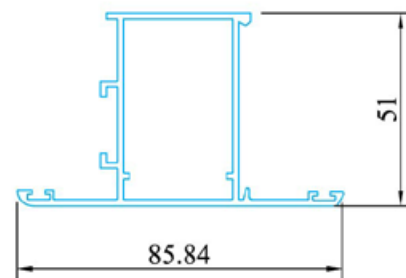

**3341**

W = 1.065 kg/m  
 T = 1.5 mm

**CỬA SỔ BẬT HỆ 100, ĐỘ DÀY TRUNG BÌNH 1.5 mm**  
CASEMENT WINDOW 100, AVERAGE THICKNESS 1.5 mm

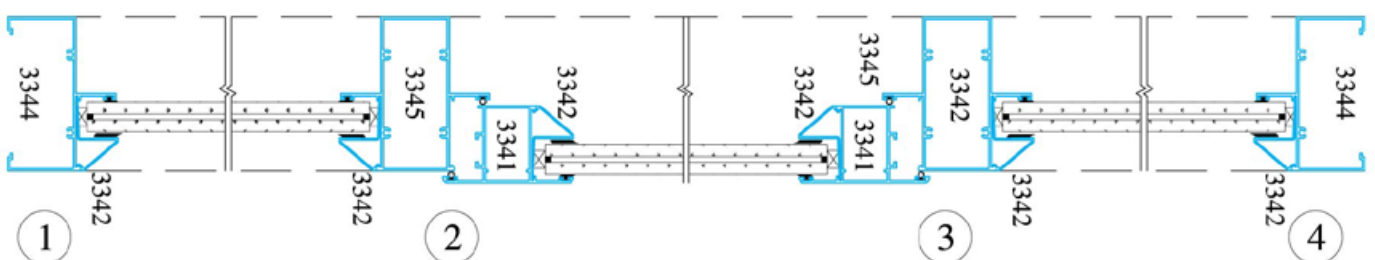
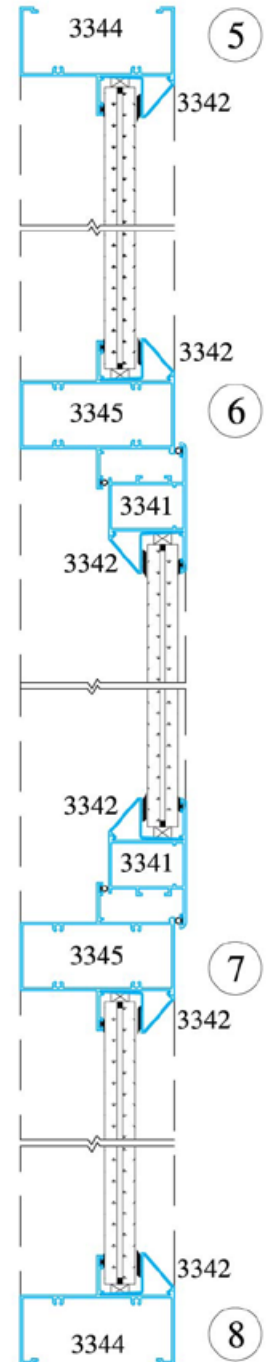
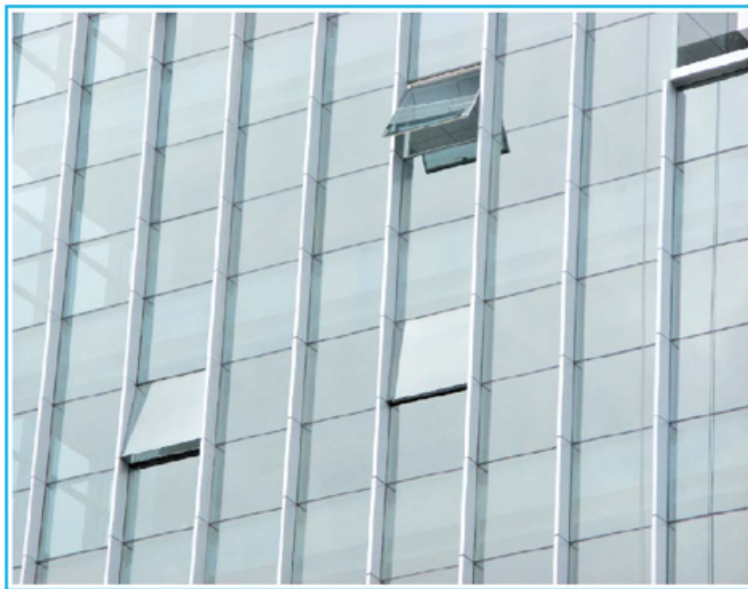
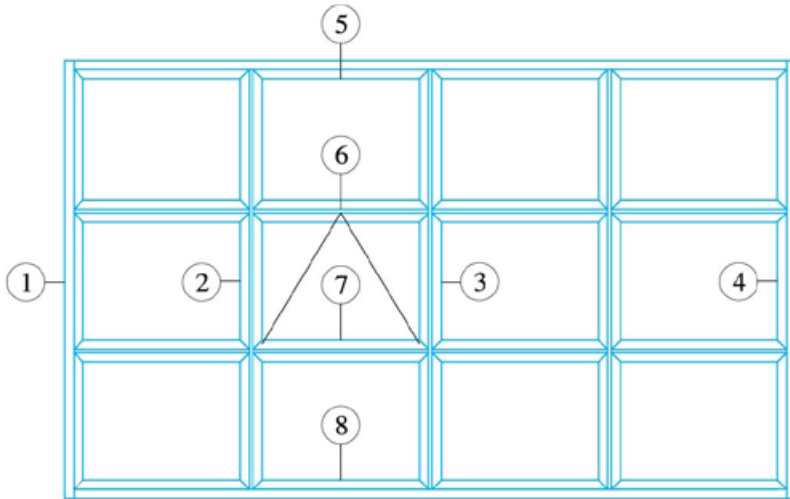

**CỬA ĐI MỞ QUAY & VÁCH NGẮN HỆ 100, ĐỘ DÀY TRUNG BÌNH 1.3 - 1.5 mm**  
**SWING DOOR & PARTITION 100, AVERAGE THICKNESS 1.3 - 1.5 mm**

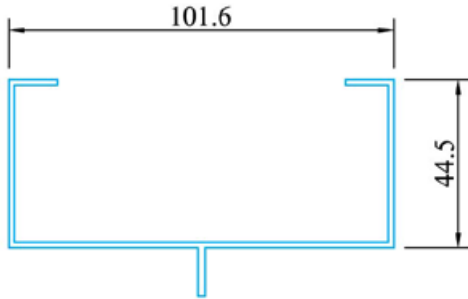

821

W = 0.864 kg/m  
 T = 1.4 mm

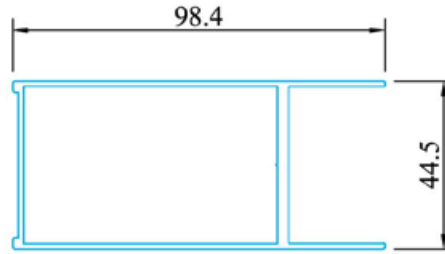

816

W = 1.268 kg/m  
 T = 1.4 mm

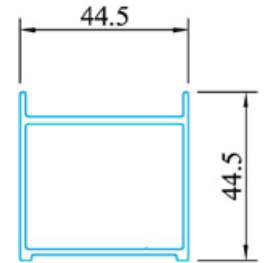

817

W = 0.734 kg/m  
 T = 1.4 mm

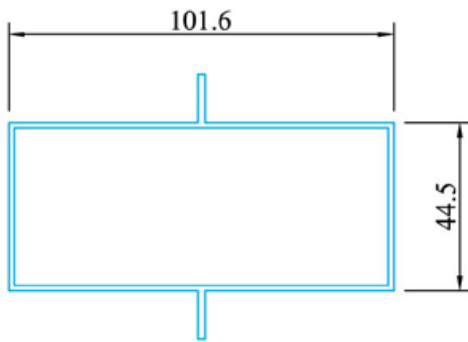

823

W = 1.221 kg/m  
 T = 1.4 mm

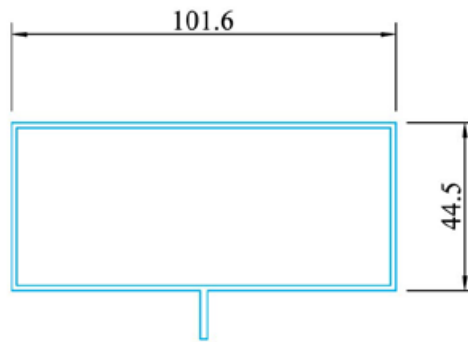

822

W = 1.153 kg/m  
 T = 1.4 mm

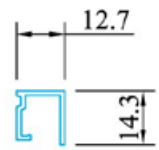

818

W = 0.131 kg/m  
 T = 1.0 mm

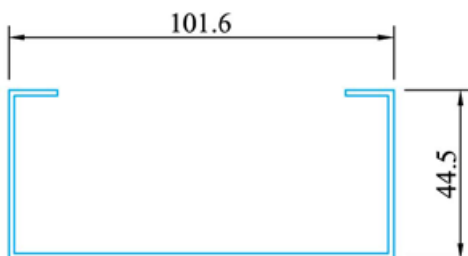

820

W = 0.796 kg/m  
 T = 1.4 mm

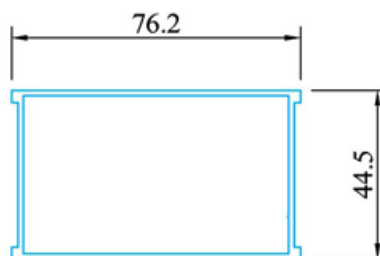

824

W = 0.921 kg/m  
 T = 1.4 mm

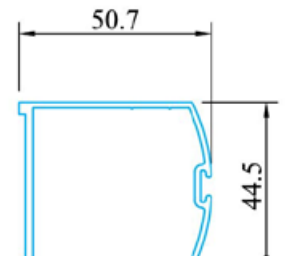

814

W = 0.820 kg/m  
 T = 1.5 mm

819

W = 0.212 kg/m  
 T = 1.2 mm

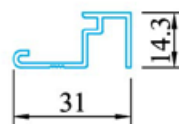

**CỬA ĐI MỞ QUAY & VÁCH NGẮN HỆ 100, ĐỘ DÀY TRUNG BÌNH 1.3 - 1.5 mm**  
**SWING DOOR & PARTITION 100, AVERAGE THICKNESS 1.3 - 1.5 mm**

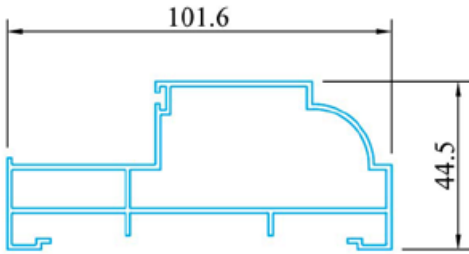

3319

W = 1.162 kg/m  
 T = 1.3 mm

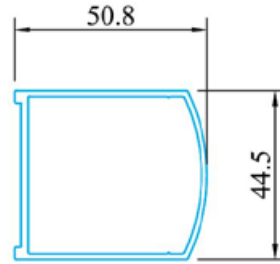

815

W = 0.787 kg/m  
 T = 1.5 mm

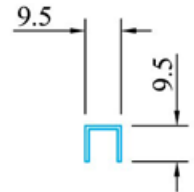

724

W = 0.065 kg/m  
 T = 0.9 mm

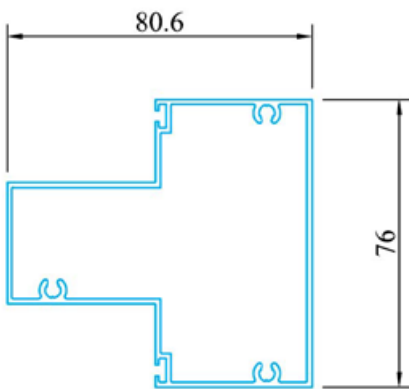

3379

W = 1.251 kg/m  
 T = 1.3 mm

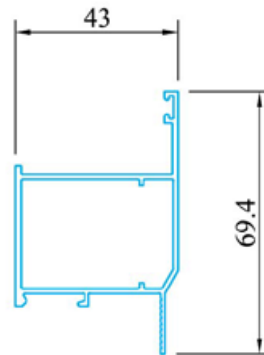

3320

W = 0.727 kg/m  
 T = 1.3 mm

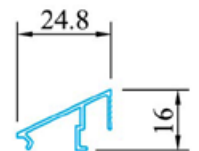

3380

W = 0.137 kg/m  
 T = 0.9 mm

**CỬA ĐI MỞ QUAY & VÁCH NGẮN HỆ 100, ĐỘ DÀY TRUNG BÌNH 1.3 - 1.5 mm**  
*SWING DOOR & PARTITION 100, AVERAGE THICKNESS 1.3 - 1.5 mm*

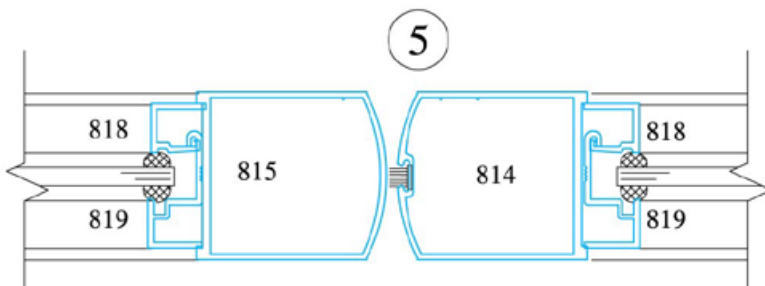
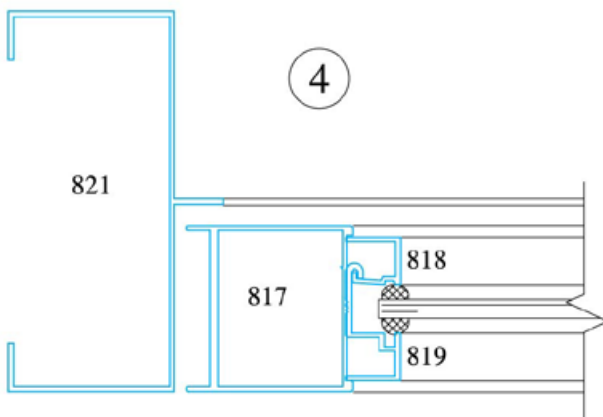
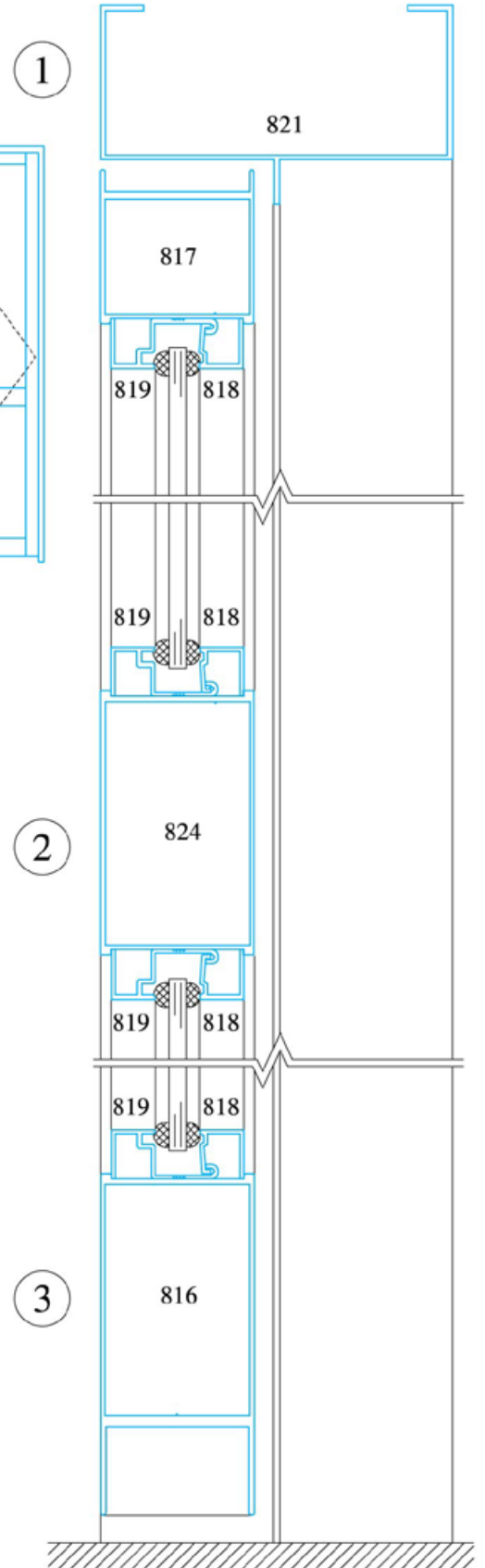
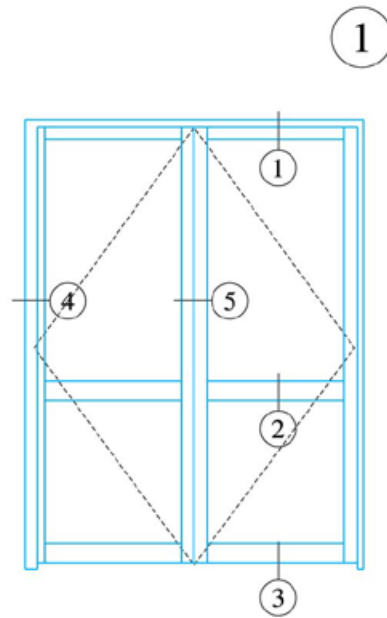

**CỬA ĐI MỞ QUAY & VÁCH NGẮN HỆ 100, ĐỘ DÀY TRUNG BÌNH 1.3 - 1.5 mm**  
*SWING DOOR & PARTITION 100, AVERAGE THICKNESS 1.3 - 1.5 mm*

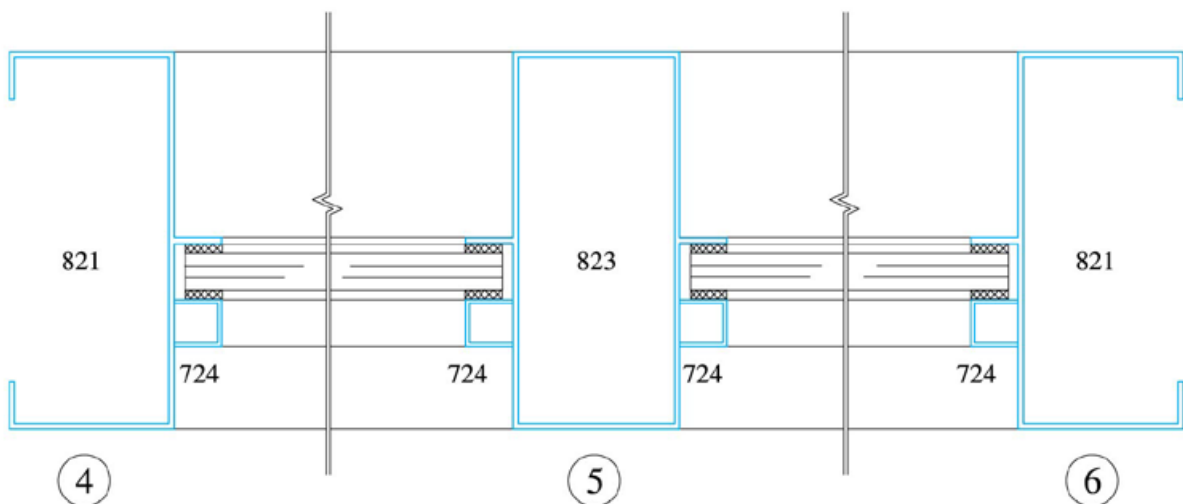
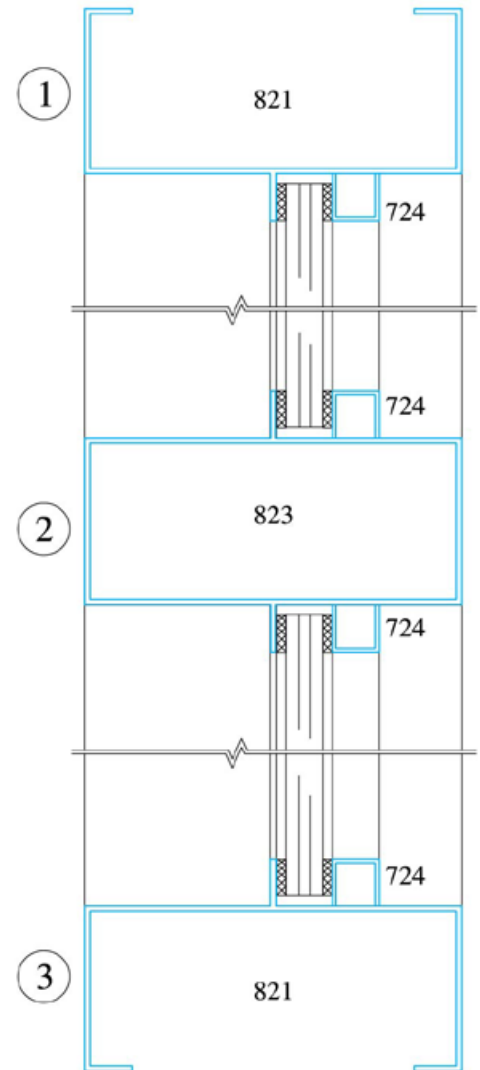
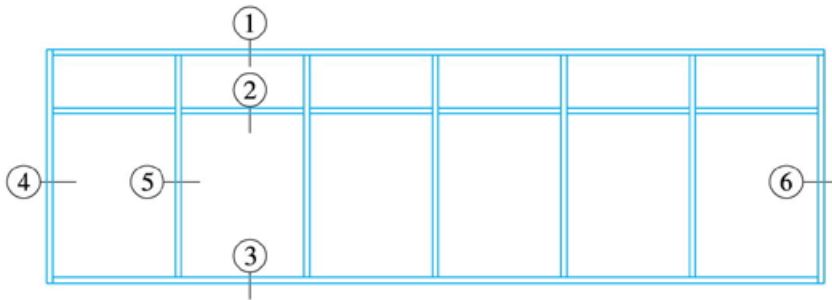

**CỬA ĐI MỞ QUAY & VÁCH NGẮN HỆ 100, ĐỘ DÀY TRUNG BÌNH 1.3 - 1.5 mm**  
*SWING DOOR & PARTITION 100, AVERAGE THICKNESS 1.3 - 1.5 mm*

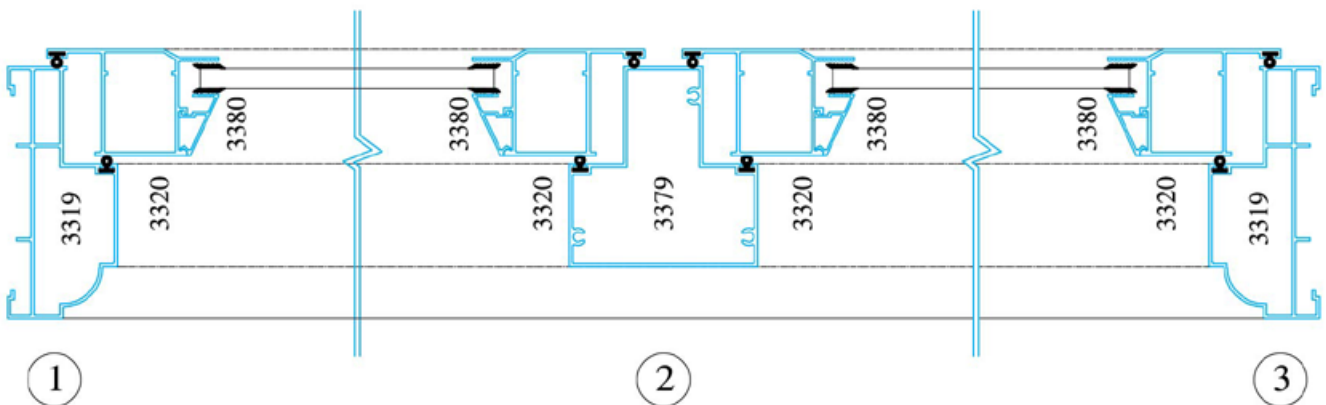
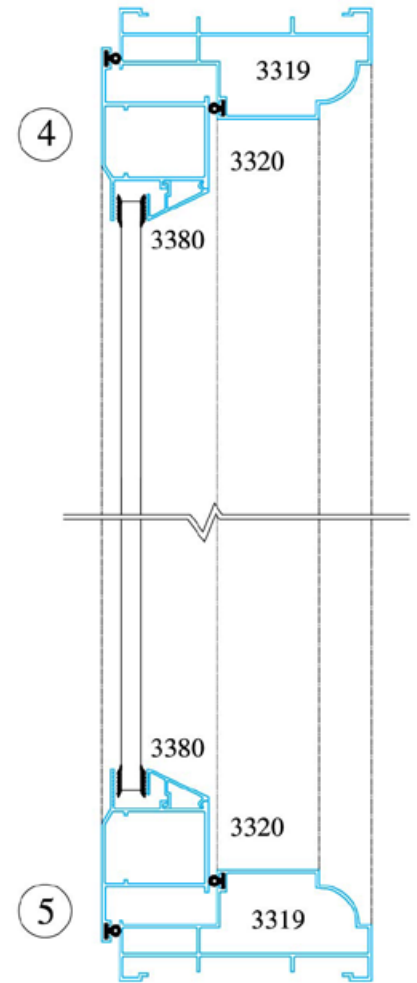
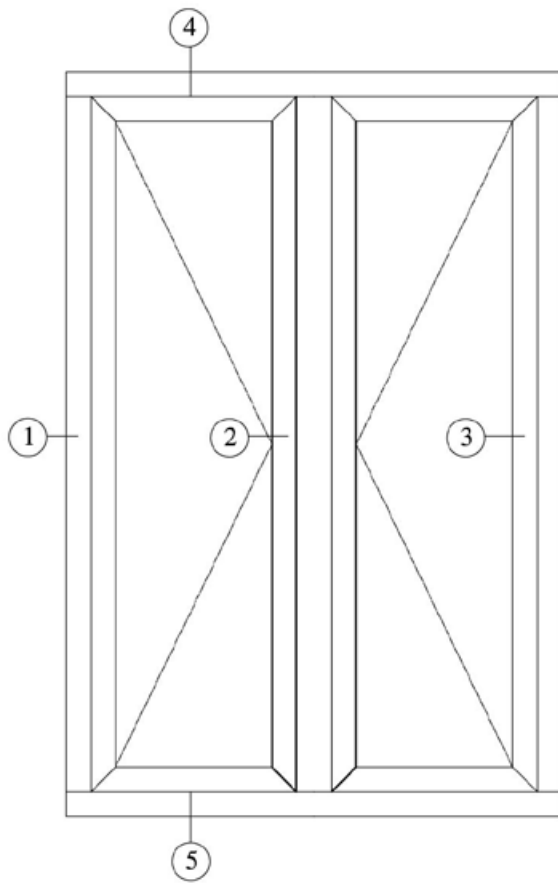

**CỬA ĐI MỞ QUAY & VÁCH NGĂN HỆ 100, ĐỘ DÀY TRUNG BÌNH 1.3 - 1.5 mm**  
*SWING DOOR & PARTITION 100, AVERAGE THICKNESS 1.3 - 1.5 mm*



**CỬA ĐI MỞ QUAY & VÁCH NGẮN HỆ 100, ĐỘ DÀY TRUNG BÌNH 1.3 - 1.5 mm**  
*SWING DOOR & PARTITION 100, AVERAGE THICKNESS 1.3 - 1.5 mm*



**CỬA ĐI & CỬA SỔ LÙA HỆ 100, ĐỘ DÀY TRUNG BÌNH 1.2 mm**  
**SLIDING DOOR & WINDOW 100, AVERAGE THICKNESS 1.2 mm**

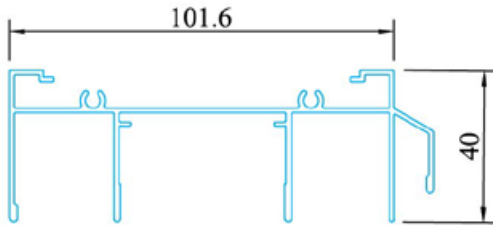

**3040**

W = 1.106 kg/m  
 T = 1.2 mm

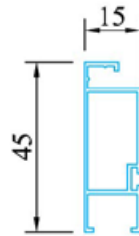

**1092**

W = 0.345 kg/m  
 T = 1.0 mm

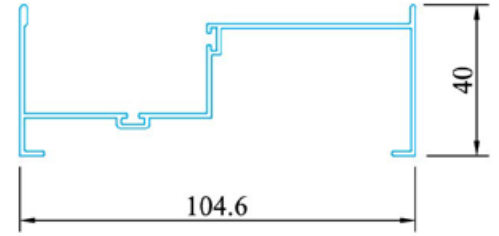

**3033**

W = 0.759 kg/m  
 T = 1.2 mm

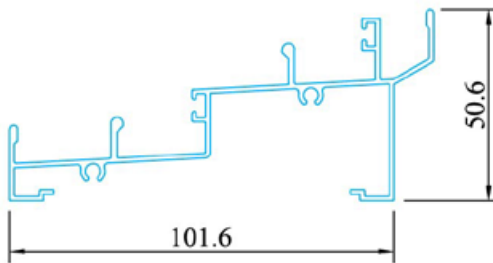

**3044**

W = 1.026 kg/m  
 T = 1.2 mm

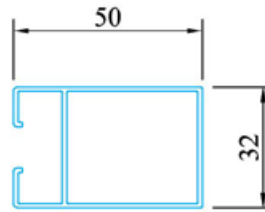

**3034**

W = 0.585 kg/m  
 T = 1.2 mm

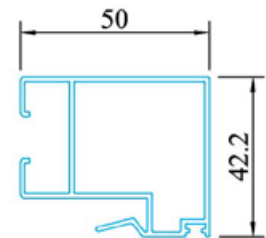

**3035**

W = 0.717 kg/m  
 T = 1.2 mm

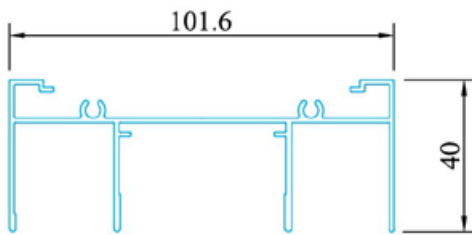

**3111**

W = 1.002 kg/m  
 T = 1.2 mm

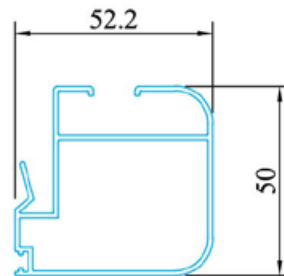

**3036**

W = 0.789 kg/m  
 T = 1.2 mm

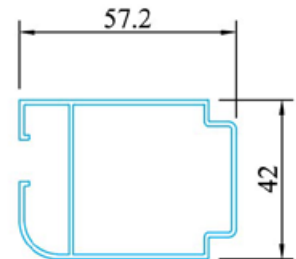

**3038**

W = 0.713 kg/m  
 T = 1.2 mm

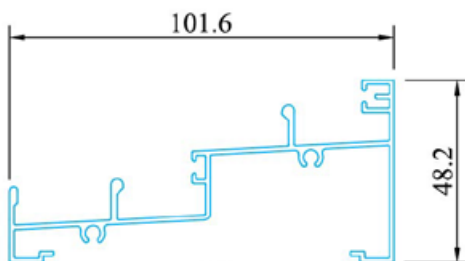

**3112**

W = 0.970 kg/m  
 T = 1.2 mm

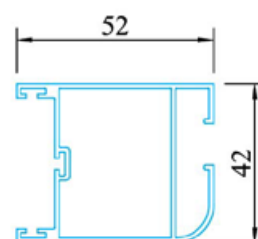

**3039**

W = 0.778 kg/m  
 T = 1.2 mm

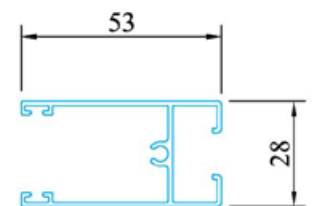

**3041**

W = 0.563 kg/m  
 T = 1.2 mm

**CỬA ĐI & CỬA SỐ LỬA HỆ 100, ĐỘ DÀY TRUNG BÌNH 1.2 mm**  
*SLIDING DOOR & WINDOW 100, AVERAGE THICKNESS 1.2 mm*

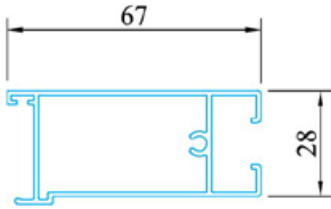

**3043**

W = 0.715 kg/m  
T = 1.2 mm

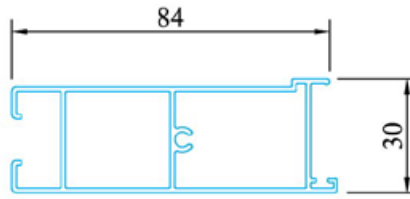

**3042**

W = 0.922 kg/m  
T = 1.2 mm

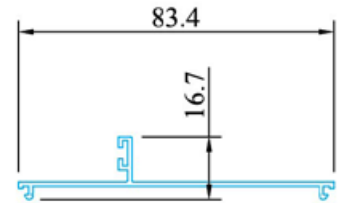

**2453**

W = 0.338 kg/m  
T = 1.1 mm

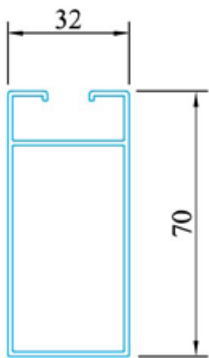

**3113**

W = 0.715 kg/m  
T = 1.2 mm

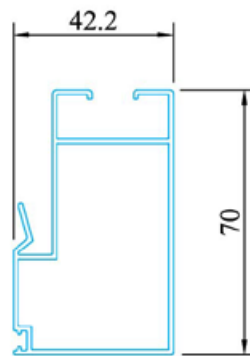

**3114**

W = 0.847 kg/m  
T = 1.2 mm

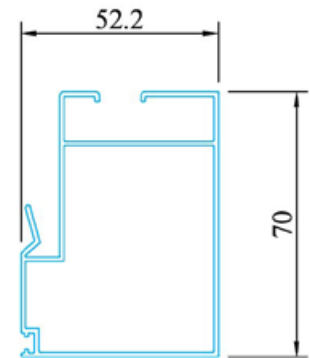

**3115**

W = 0.945 kg/m  
T = 1.2 mm

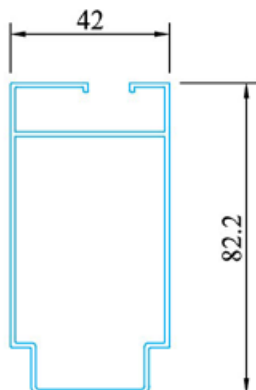

**3116**

W = 0.889 kg/m  
T = 1.2 mm

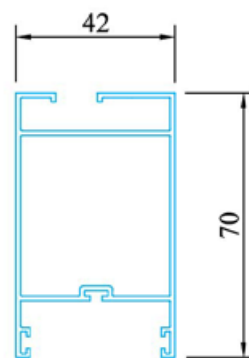

**3117**

W = 0.887 kg/m  
T = 1.2 mm

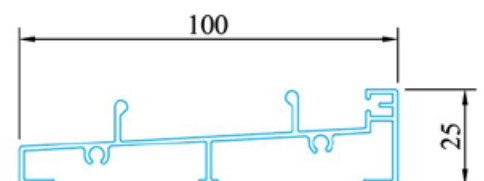

**6113**

W = 0.764 kg/m  
T = 1.2 mm

**CỬA ĐI & CỬA SỐ LỬA HỆ 100, ĐỘ DÀY TRUNG BÌNH 1.2 mm**  
*SLIDING DOOR & WINDOW 100, AVERAGE THICKNESS 1.2 mm*

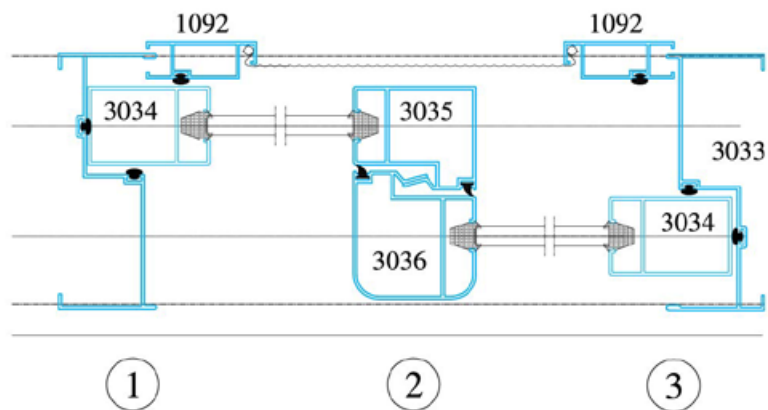
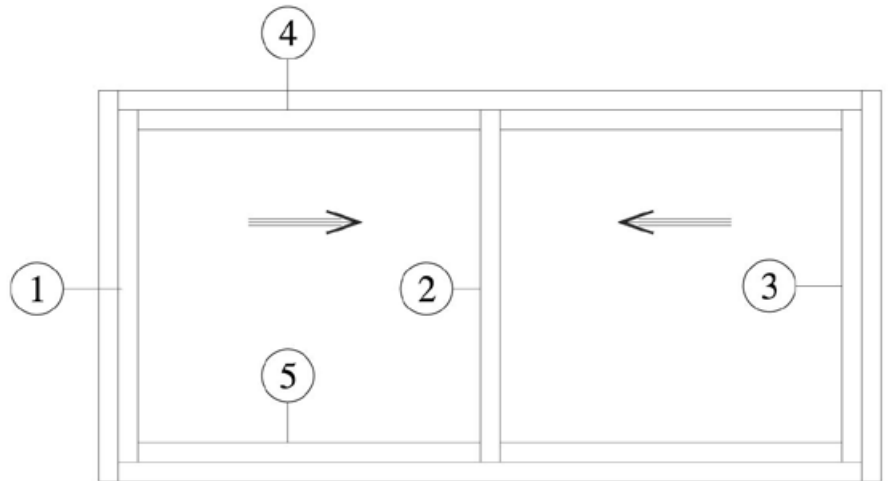
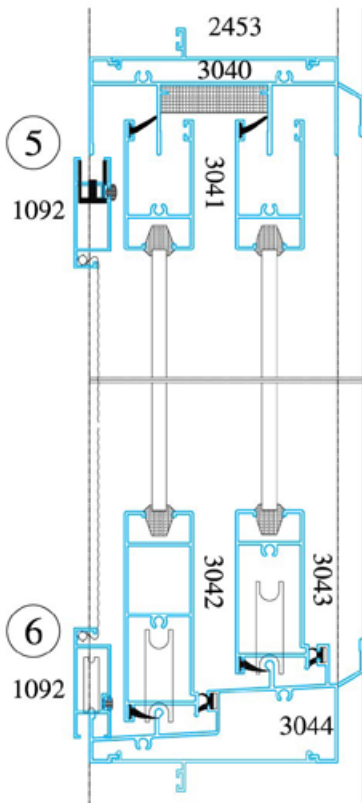

**CỬA ĐI & CỬA SỐ LỬA HỆ 100, ĐỘ DÀY TRUNG BÌNH 1.2 mm**  
*SLIDING DOOR & WINDOW 100, AVERAGE THICKNESS 1.2 mm*

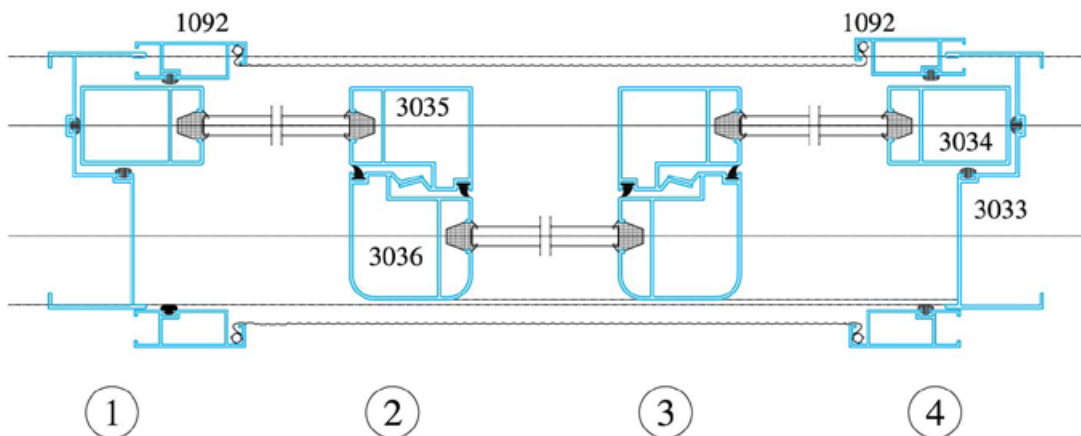
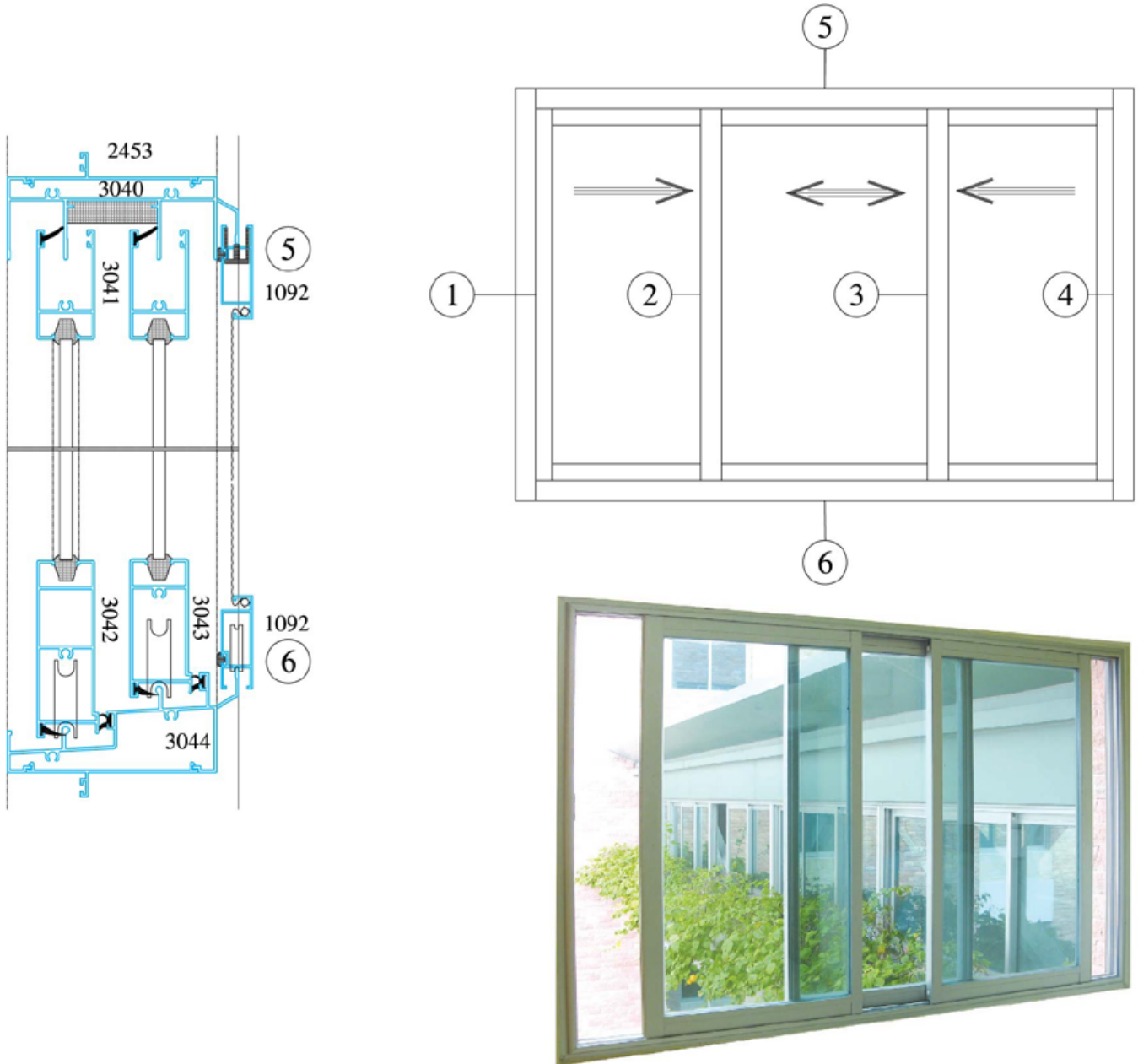

**CỬA ĐI & CỬA SỐ LỬA HỆ 100, ĐỘ DÀY TRUNG BÌNH 1.2 mm**  
*SLIDING DOOR & WINDOW 100, AVERAGE THICKNESS 1.2 mm*

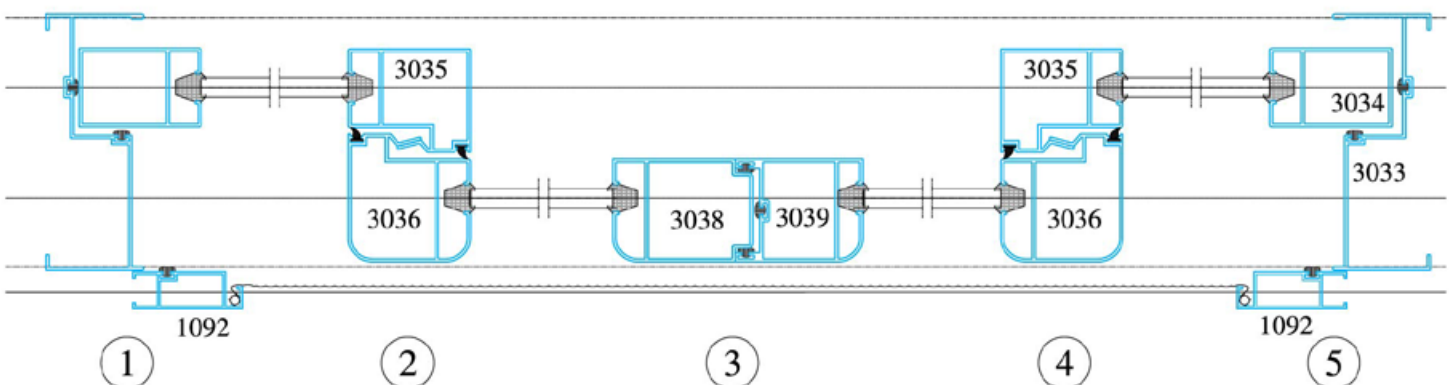
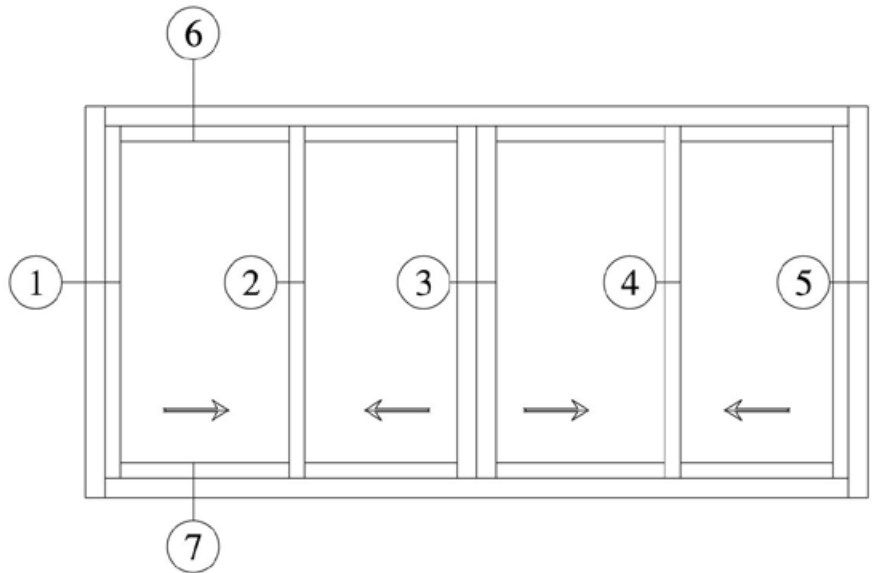
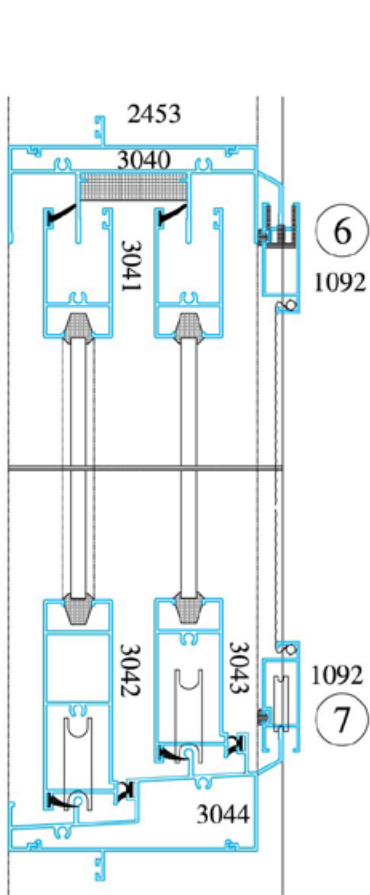

**CỬA ĐI MỞ QUAY HÊ 130, ĐỘ DÀY TRUNG BÌNH 1.1 - 1.3 mm**  
**SWING DOOR 130, AVERAGE THICKNESS 1.1 - 1.3 mm**

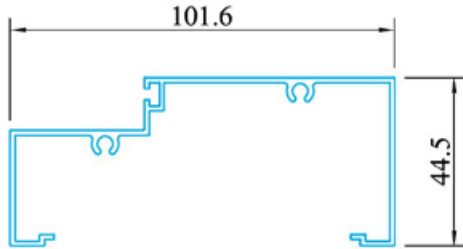

**2993**

W = 0.860 kg/m  
 T = 1.3 mm

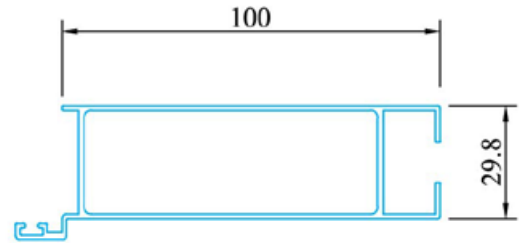

**1550**

W = 1.024 kg/m  
 T = 1.2 mm

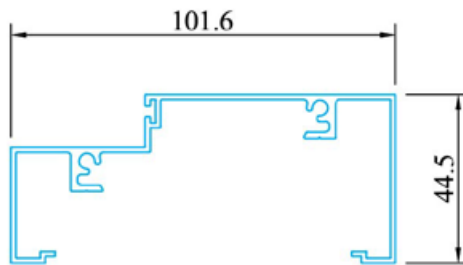

**2233**

W = 0.994 kg/m  
 T = 1.3 mm

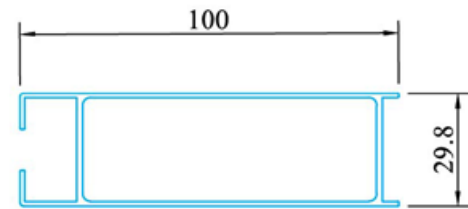

**1549**

W = 0.933 kg/m  
 T = 1.2 mm

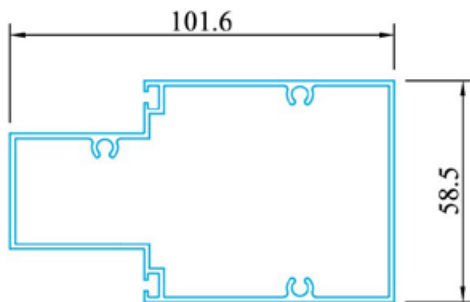

**3126**

W = 1.290 kg/m  
 T = 1.3 mm

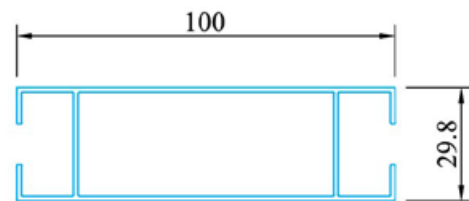

**3183**

W = 0.937 kg/m  
 T = 1.2 mm

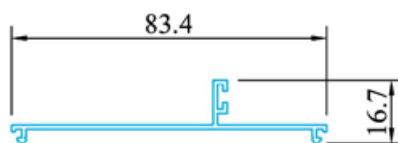

**2453**

W = 0.338 kg/m  
 T = 1.1 mm

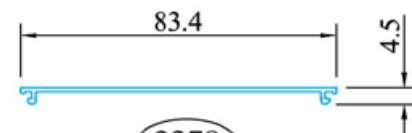

**2279**

W = 0.278 kg/m  
 T = 1.1 mm

**CỬA ĐI MỞ QUAY HỆ 130, ĐỘ DÀY TRUNG BÌNH 1.1 - 1.3 mm**  
**SWING DOOR 130, AVERAGE THICKNESS 1.1 - 1.3 mm**

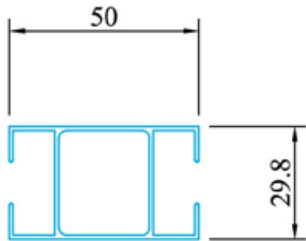

2235

W = 0.522 kg/m  
 T = 1.0 mm

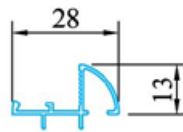

2236

W = 0.142 kg/m  
 T = 0.8 mm

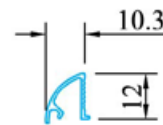

2237

W = 0.079 kg/m  
 T = 0.8 mm

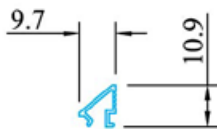

1470

W = 0.064 kg/m  
 T = 0.8 mm

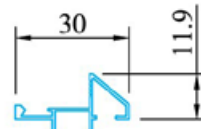

1469

W = 0.148 kg/m  
 T = 0.8 mm

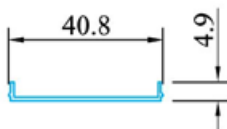

2454

W = 0.119 kg/m  
 T = 0.9 mm

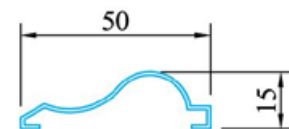

2234

W = 0.181 kg/m  
 T = 0.9 mm

**CỬA ĐI MỞ QUAY HỆ 130, ĐỘ DÀY TRUNG BÌNH 1.1 - 1.3 mm**  
*SWING DOOR 130, AVERAGE THICKNESS 1.1 - 1.3 mm*

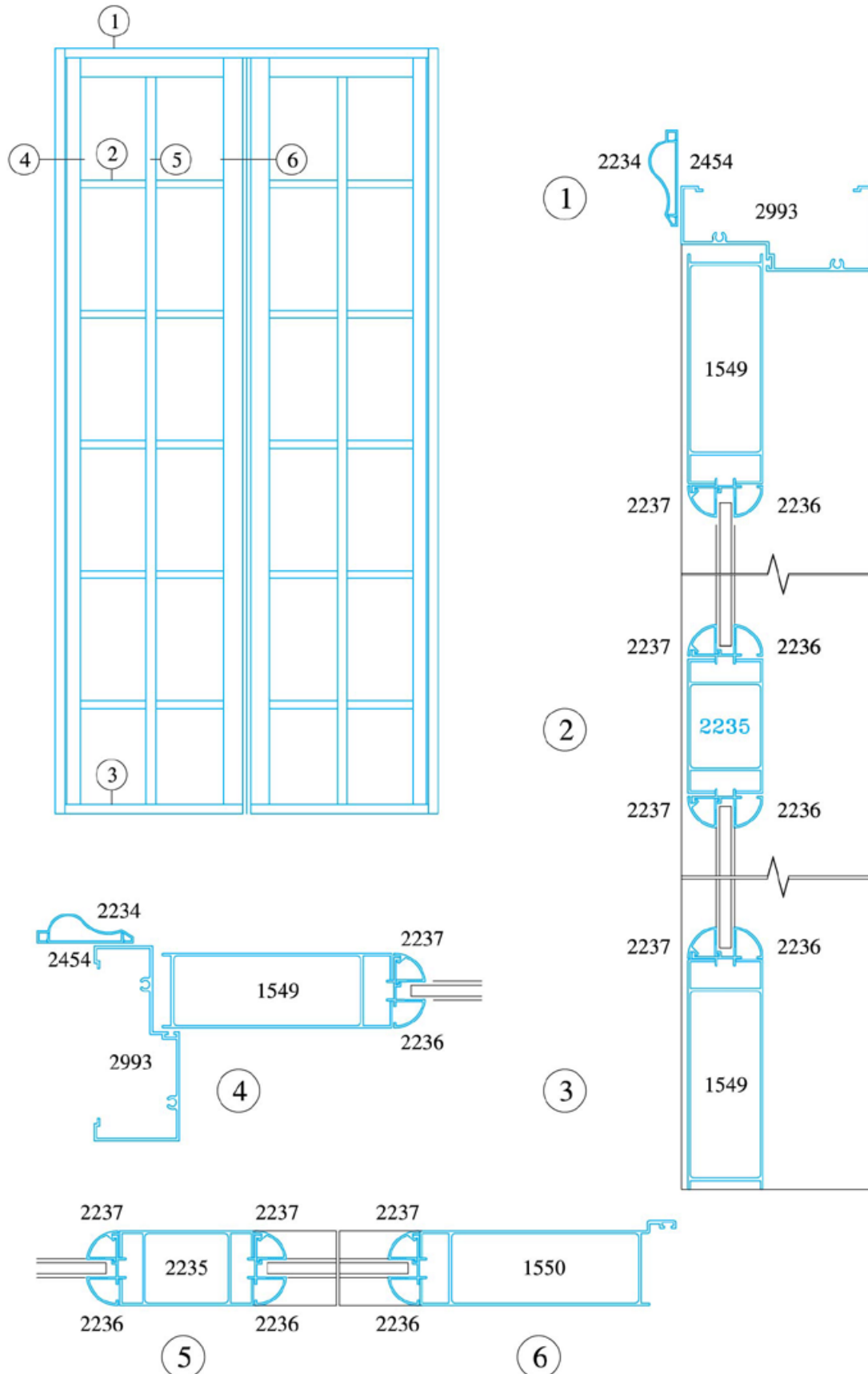

**CỬA ĐI MỞ QUAY HỆ 134, ĐỘ DÀY TRUNG BÌNH 1.2 - 1.4 mm**  
**SWING DOOR 134, AVERAGE THICKNESS 1.2 - 1.4 mm**

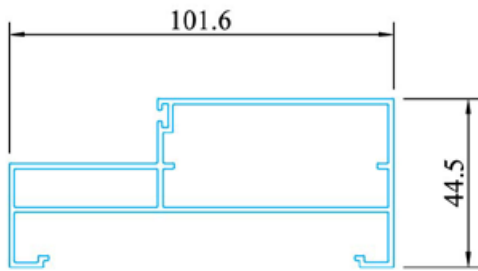

5051

W = 1.236 kg/m  
 T = 1.4 mm

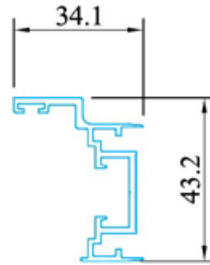

3167

W = 0.513 kg/m  
 T = 1.4 mm

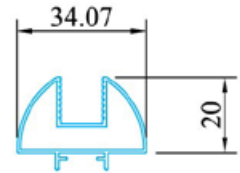

1969

W = 0.292 kg/m  
 T = 0.8 mm

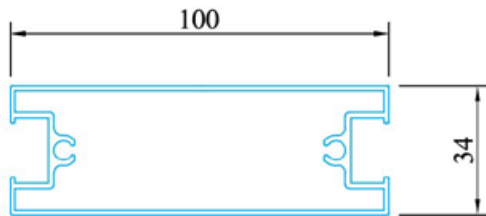

1967

W = 1.184 kg/m  
 T = 1.2 mm

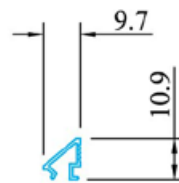

1470

W = 0.064 kg/m  
 T = 0.8 mm

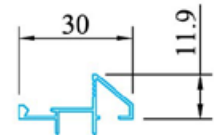

1469

W = 0.148 kg/m  
 T = 0.8 mm

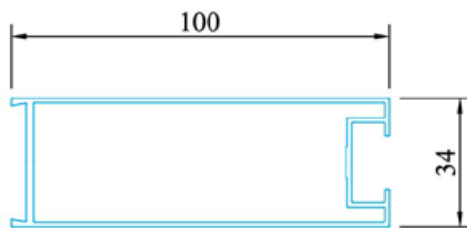

1966

W = 1.005 kg/m  
 T = 1.2 mm

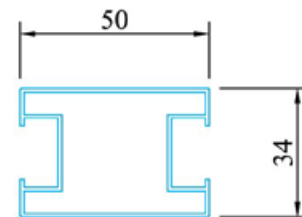

1968

W = 0.573 kg/m  
 T = 1.0 mm

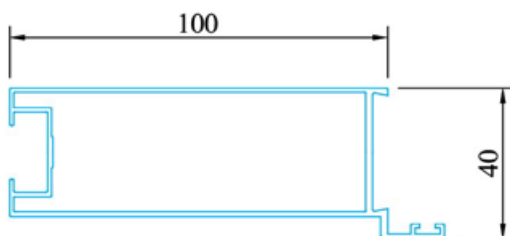

1965

W = 1.063 kg/m  
 T = 1.2 mm

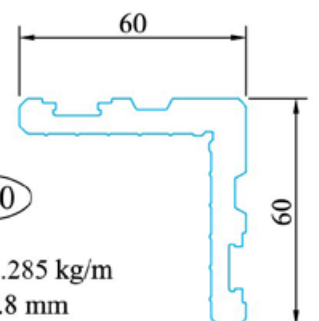

5050

W = 2.285 kg/m  
 T = 9.8 mm

**CỬA ĐI MỞ QUAY HỆ 134, ĐỘ DÀY TRUNG BÌNH 1.2 - 1.4 mm**  
*SWING DOOR 134, AVERAGE THICKNESS 1.2 - 1.4 mm*

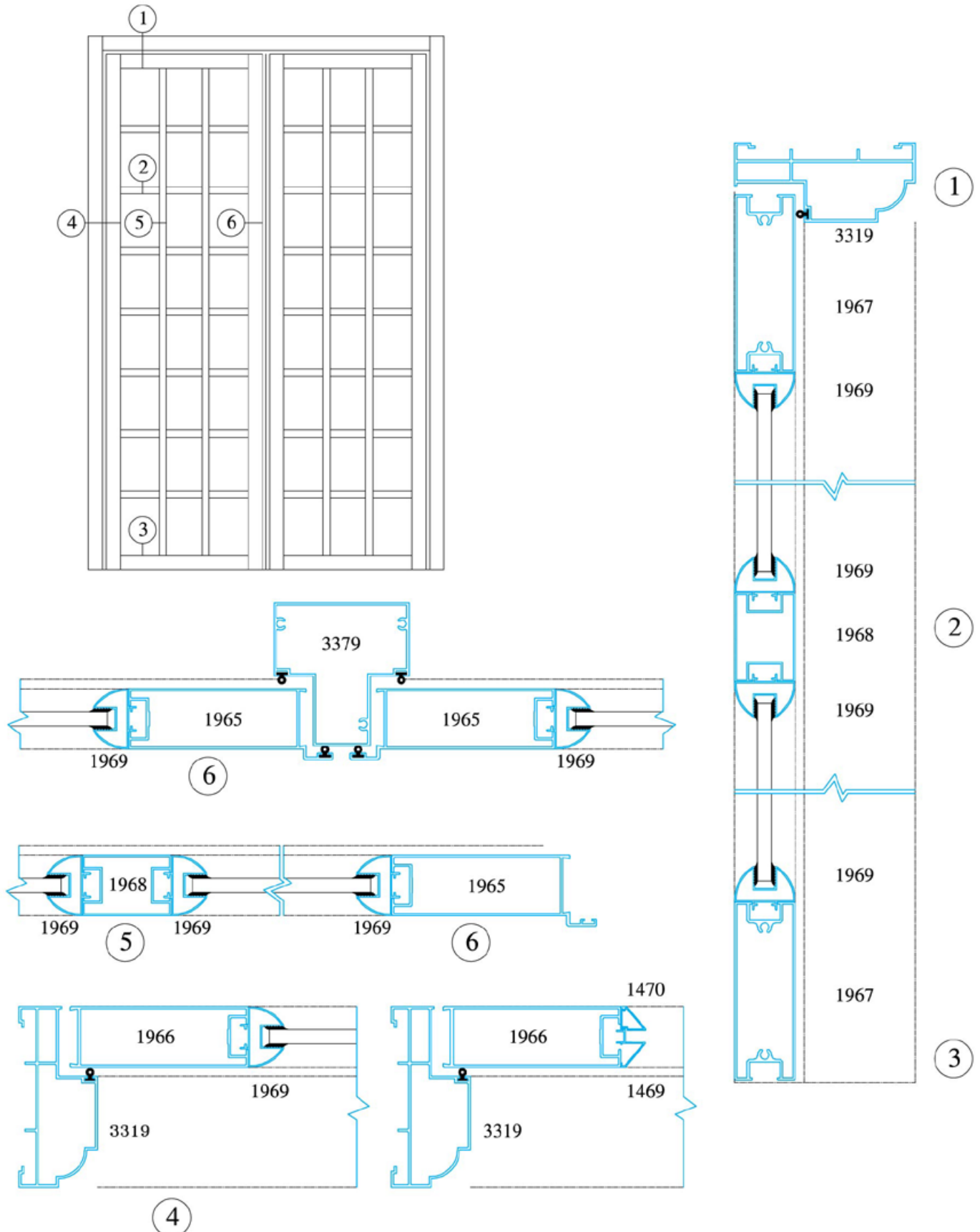

**CỬA ĐI MỞ QUAY HỆ 134, ĐỘ DÀY TRUNG BÌNH 1.2 - 1.4 mm**  
*SWING DOOR 134, AVERAGE THICKNESS 1.2 - 1.4 mm*

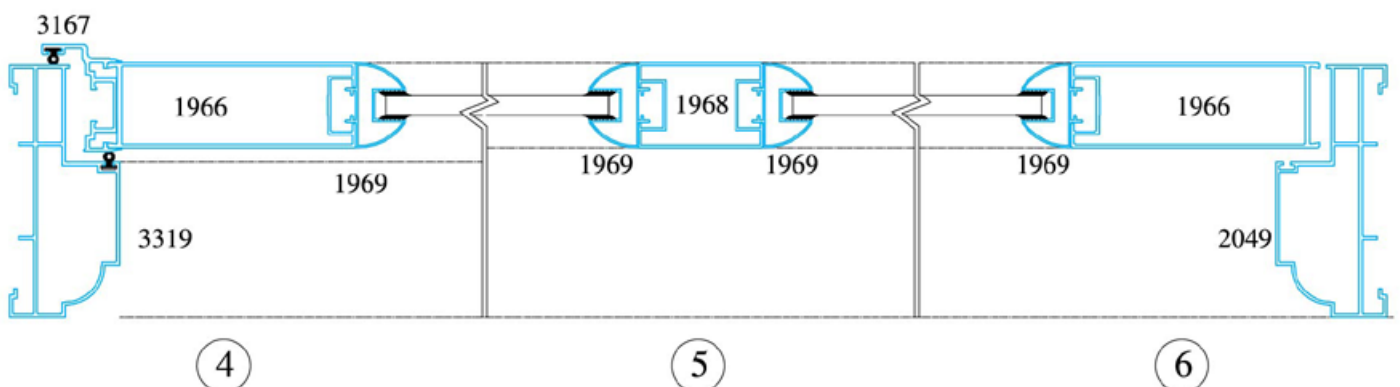
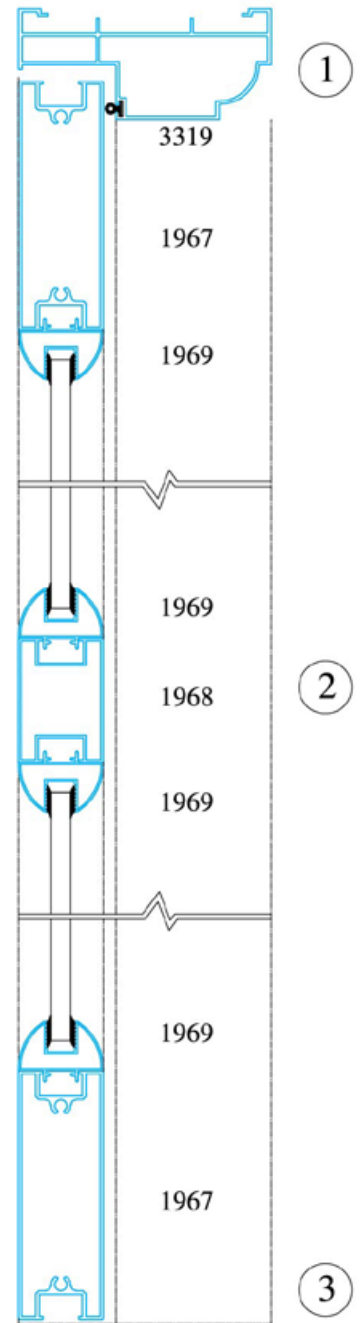
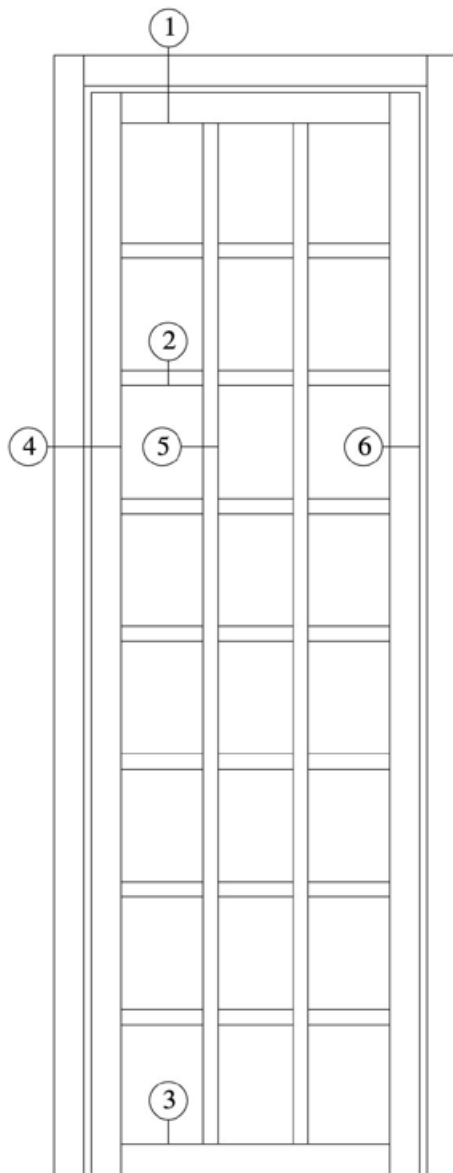

**CỬA ĐI MỞ QUAY HỆ 134, ĐỘ DÀY TRUNG BÌNH 1.2 - 1.4 mm**  
*SWING DOOR 134, AVERAGE THICKNESS 1.2 - 1.4 mm*



**SAPA BEN THANH ALUMINIUM PROFILES CO., LTD.**

**Add:** Lot C, Street No. 3, Binh Chieu IP, Tam Binh Ward, Ho Chi Minh City, Vietnam

**Tel:** (028) 3896 8780

**Email:** [sales@sapabtg.com](mailto:sales@sapabtg.com) - **Website:** [www.sapabtg.com](http://www.sapabtg.com)