



# CATALOGUE

## **NHÔM XÂY DỰNG MẶT DỰNG**

*ALUMINIUM FOR BUILDING & CONSTRUCTION  
CURTAIN WALL*

## MỤC LỤC CONTENTS

	Trang / Page
THƯ NGỎ / <i>OPEN LETTER</i> .....	1
MẶT DỰNG HỆ 80 / <i>CURTAIN WALL 80</i> .....	2-6
MẶT DỰNG HỆ 91 / <i>CURTAIN WALL 91</i> .....	7-18
MẶT DỰNG HỆ 108 / <i>CURTAIN WALL 108</i> .....	18-19
MẶT DỰNG HỆ 110 / <i>CURTAIN WALL 110</i> .....	21-23
MẶT DỰNG HỆ 115 / <i>CURTAIN WALL 115</i> .....	24-26
MẶT DỰNG HỆ 120 / <i>CURTAIN WALL 120</i> .....	27-28
MẶT DỰNG SEMI-UNITIZED HỆ 120 / <i>SEMI-UNITIZED CURTAIN WALL 120</i> .....	29-31
MẶT DỰNG HỆ 140 / <i>CURTAIN WALL 140</i> .....	32-39



## THƯ NGỎ OPEN LETTER

Kính gửi Quý Khách hàng và đối tác,

Công ty TNHH Nhôm định hình Sapa Bến Thành (Sapa BTG) chân thành cảm ơn Quý khách hàng đã luôn tin tưởng và đồng hành cùng chúng tôi.

Được thành lập từ năm 1996, Sapa BTG có 30 năm kinh nghiệm trên thị trường, chuyên sản xuất và cung cấp sản phẩm nhôm định hình chất lượng cao, đáp ứng theo các tiêu chuẩn quốc tế (như JIS, ASTM, EN, AS/NZS, AA, ISO...).

Sản phẩm được sử dụng phôi nhôm chính phẩm, xử lý bề mặt cao cấp bằng công nghệ hiện đại và gia công cơ khí hoàn chỉnh, nên ứng dụng rộng rãi trong hầu hết các lĩnh vực, từ kiến trúc xây dựng, trang trí nội thất, gia dụng đến các ngành công nghiệp đòi hỏi kỹ thuật cao như cơ khí, điện, điện tử, vận tải, ô tô, đóng tàu, năng lượng (mặt trời và gió).

Quan điểm kinh doanh được xây dựng dựa trên mối quan hệ mật thiết với khách hàng và đặt chất lượng lên hàng đầu. Đây là nền tảng giúp Sapa BTG trở thành đối tác chiến lược và nhà cung cấp uy tín của nhiều doanh nghiệp lớn trong và ngoài nước. Chúng tôi tin rằng với năng lực và kinh nghiệm chuyên sâu, Sapa BTG sẽ giúp quý khách hàng tối ưu hóa chi phí thông qua những giải pháp kỹ thuật hợp lý.

Sapa BTG mong muốn trở thành đối tác chiến lược đồng hành và đóng góp vào sự phát triển bền vững của Quý khách hàng.

Trân trọng,

Sapa BTG.

Dear valued customers and partners,

Sapa Ben Thanh Extrusion Co., Ltd. (Sapa BTG) wishes to extend its sincere gratitude for your consistent trust and partnership.

Established in 1996, Sapa BTG now stands on three decades of proven experience in the market. We are dedicated to manufacturing and supplying the high-quality aluminium extrusion product, compliant to the international standards (including JIS, ASTM, EN, AS/NZS, AA, ISO, etc.).

Our products are extruded from the primary aluminum billet, featuring advanced surface treatment technologies and the meticulous mechanical machining. This ensures their wide application across diverse sectors: Architecture & Construction, Interior and External Furniture, and Household Goods, as well as highly demanding industrial fields such as Mechanical, Electrical, Electronics, Transportation, Automotive, Shipbuilding, and Renewable Energy (Solar and Wind).

Our business motto is based on close relationships with customers and the dedication to quality excellence. This foundation has established Sapa BTG as a strategic partner and trusted supplier to many leading companies, both locally and globally. We are confident that our in-depth expertise and operational capacity will assist you in achieving the cost-efficiency via practical engineering solutions.

Sapa BTG looks forward to serving as your trusted strategic partner, actively contributing to your success and sustainable growth for years to come.

Sincerely,

Sapa BTG.

**MẶT DỰNG HỆ 80, ĐỘ DÀY TRUNG BÌNH 1.8 mm**  
**CURTAIN WALL 80, AVERAGE THICKNESS 1.8 mm**

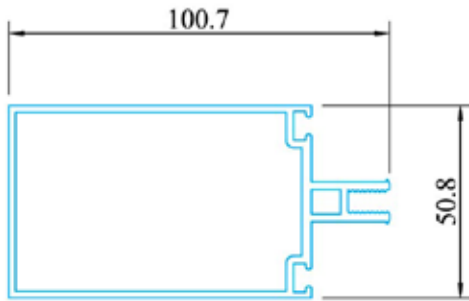

1484

W = 1.645 kg/m  
 T = 1.8 mm

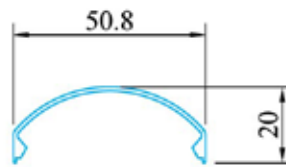

1485

W = 0.255 kg/m  
 T = 1.1 mm

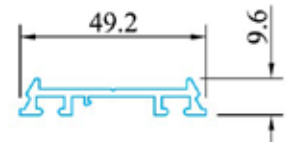

1486

W = 0.428 kg/m  
 T = 2.0 mm

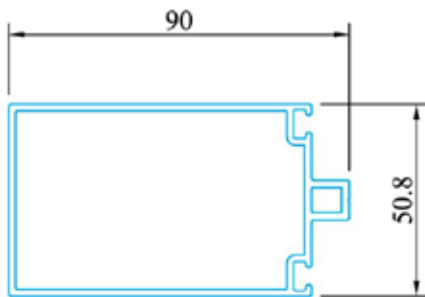

5417

W = 1.436 kg/m  
 T = 1.8 mm

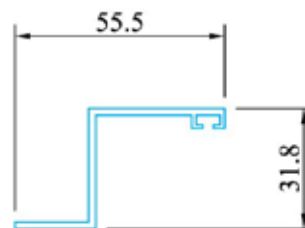

3026

W = 0.451 kg/m  
 T = 1.8 mm

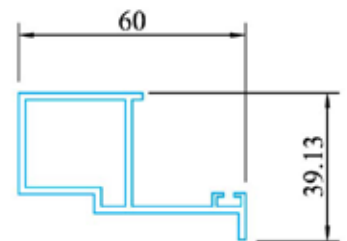

3027

W = 0.794 kg/m  
 T = 1.8 mm

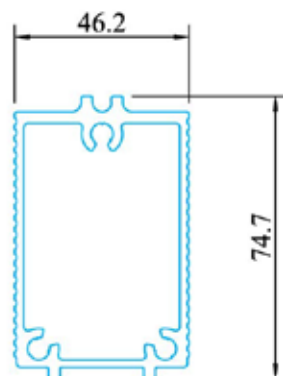

3726

W = 1.780 kg/m  
 T = 2.0 mm

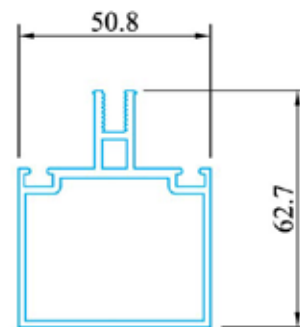

1483

W = 1.311 kg/m  
 T = 1.8 mm

**MẶT DỰNG HỆ 80, ĐỘ DÀY TRUNG BÌNH 1.8 mm**  
*CURTAIN WALL 80, AVERAGE THICKNESS 1.8 mm*

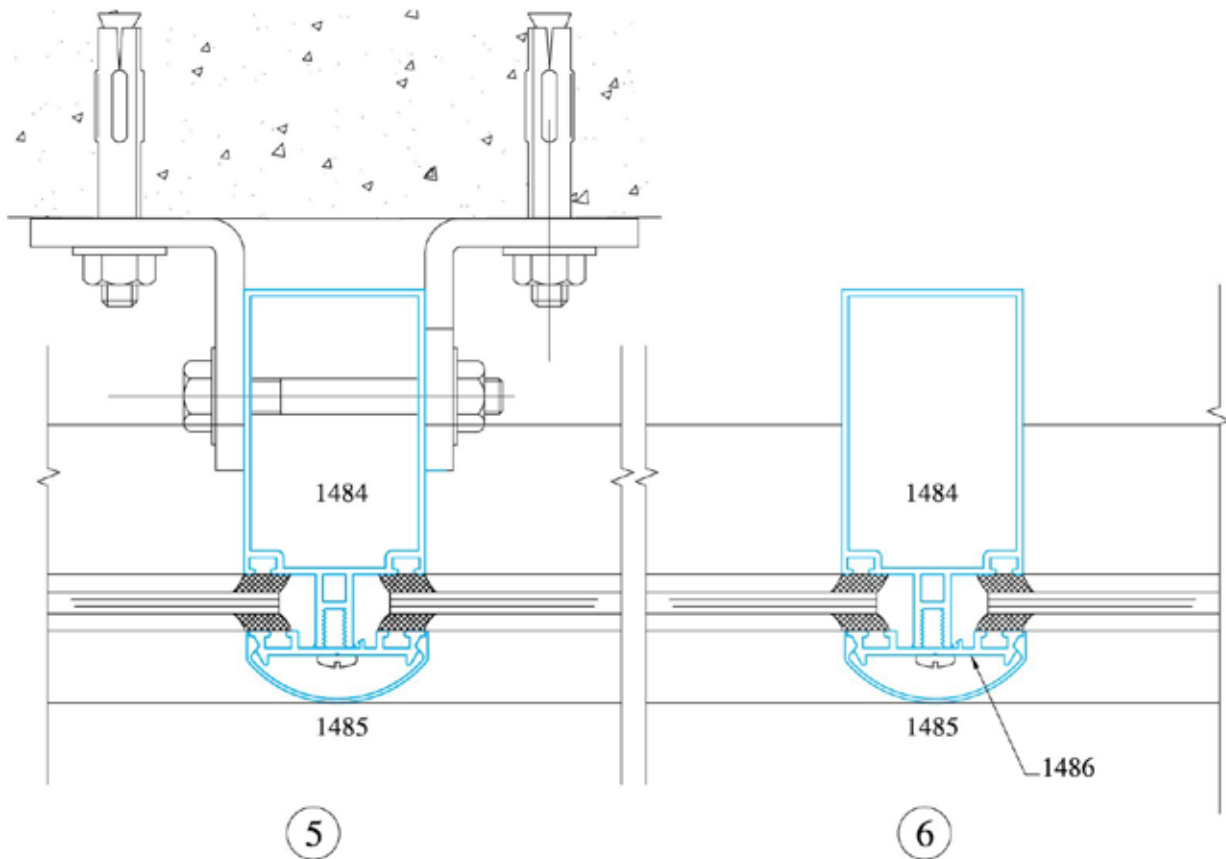
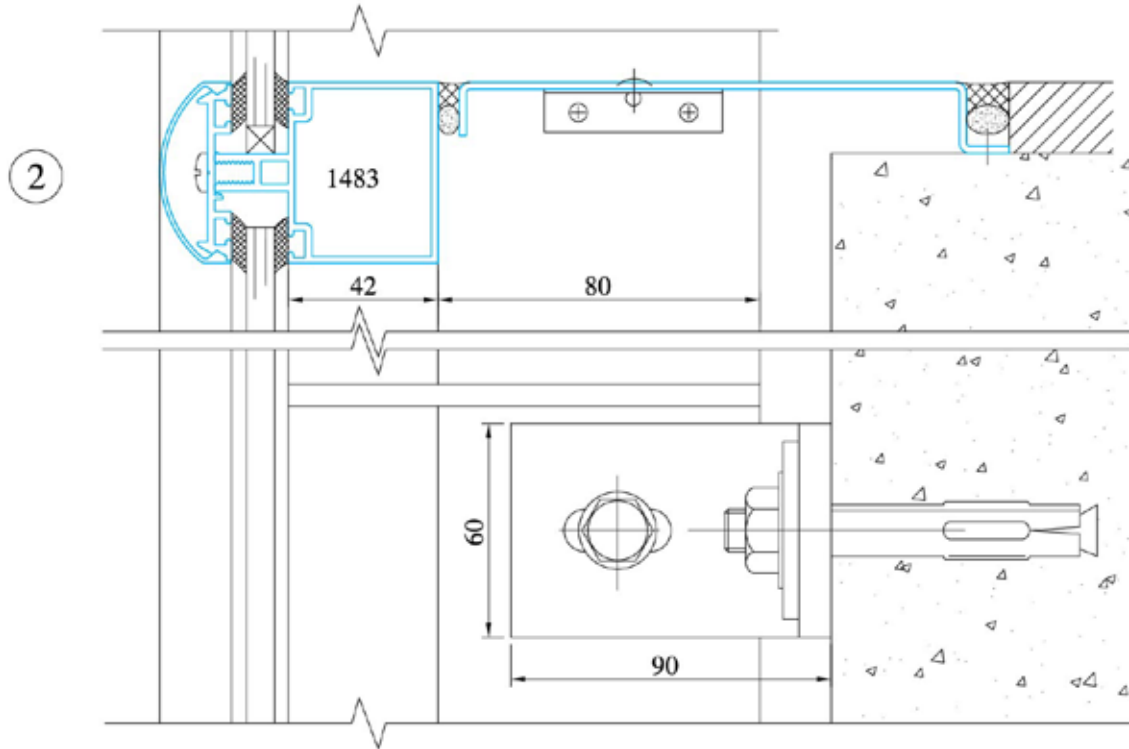

**MẶT DỰNG HỆ 80, ĐỘ DÀY TRUNG BÌNH 1.8 mm**  
*CURTAIN WALL 80, AVERAGE THICKNESS 1.8 mm*

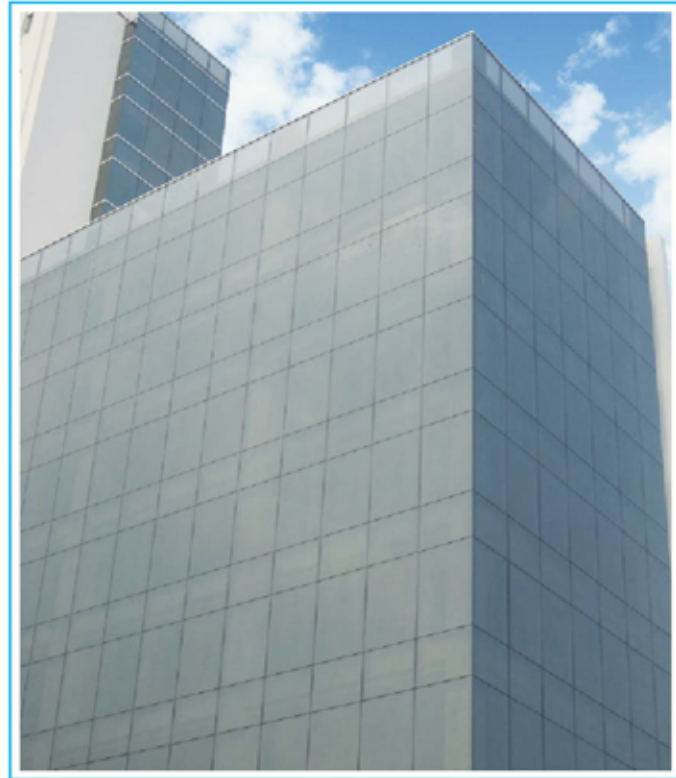

4

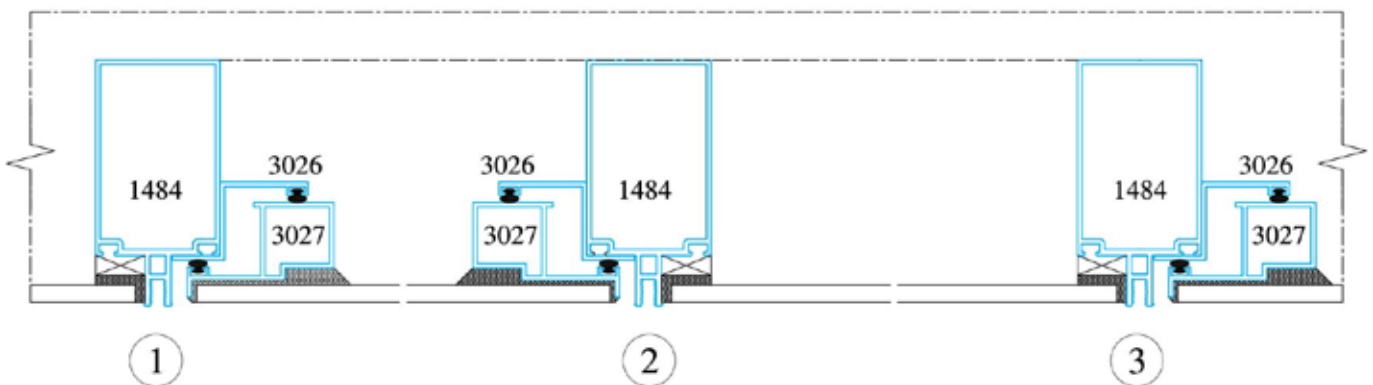
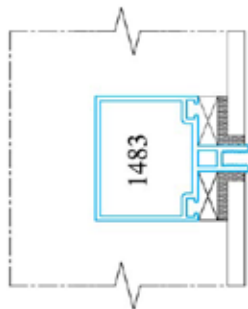

**MẶT DỰNG HỆ 80, ĐỘ DÀY TRUNG BÌNH 1.8 mm**  
*CURTAIN WALL 80, AVERAGE THICKNESS 1.8 mm*

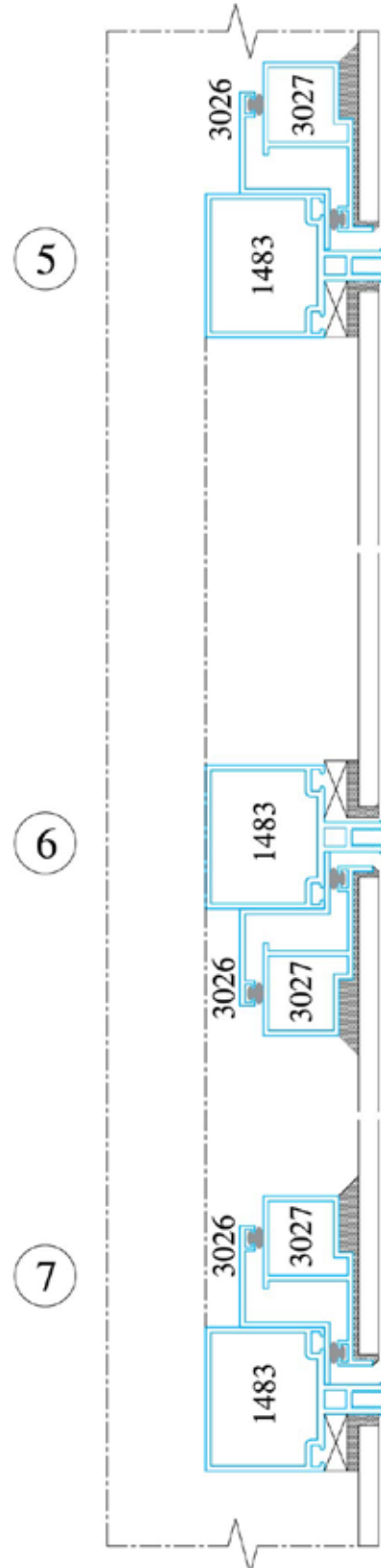
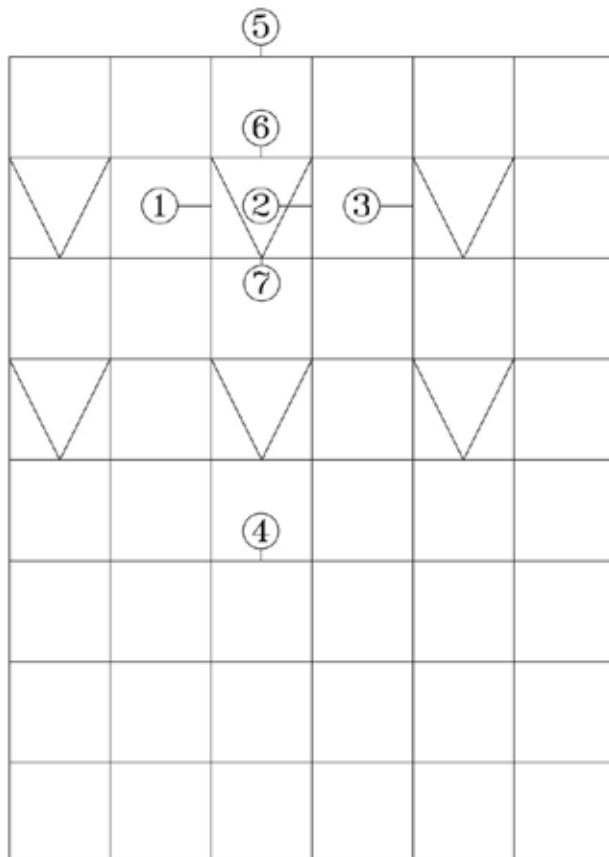

**MẶT DỰNG HỆ 80, ĐỘ DÀY TRUNG BÌNH 1.8 mm**  
*CURTAIN WALL 80, AVERAGE THICKNESS 1.8 mm*



**MẶT DỰNG HỆ 91, ĐỘ DÀY TRUNG BÌNH 2.3 - 2.5 mm**  
**CURTAIN WALL 91, AVERAGE THICKNESS 2.3 - 2.5 mm**

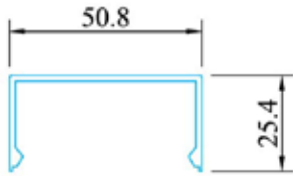

1066

W = 0.424 kg/m  
T = 1.5 mm



1067

W = 0.532 kg/m  
T = 2.8 mm

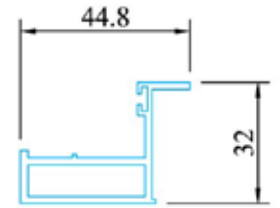

1402

W = 0.597 kg/m  
T = 1.8 mm

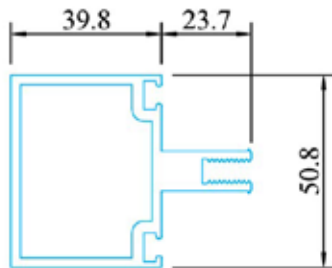

1068

W = 1.723 kg/m  
T = 2.5 mm

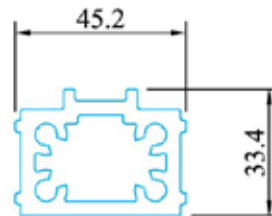

3338

W = 1.695 kg/m  
T = 3.8 mm

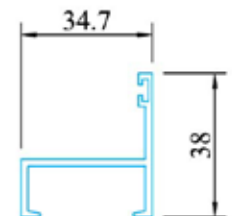

1401

W = 0.449 kg/m  
T = 1.8 mm

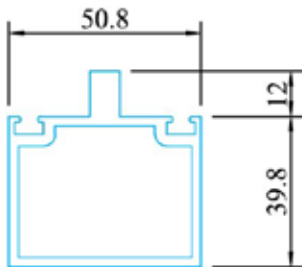

2749

W = 1.513 kg/m  
T = 2.5 mm

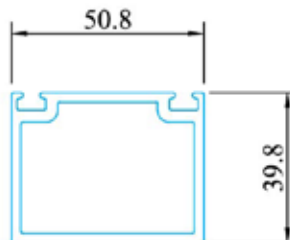

3642

W = 1.255 kg/m  
T = 2.3 mm

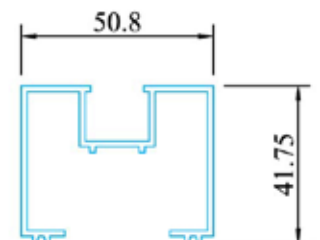

1350

W = 1.009 kg/m  
T = 2.0 mm

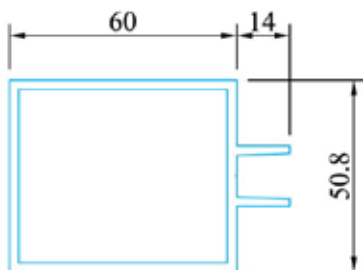

1349

W = 1.599 kg/m  
T = 2.5 mm

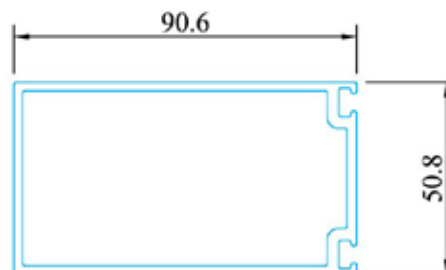

3641

W = 1.829 kg/m  
T = 2.3 mm

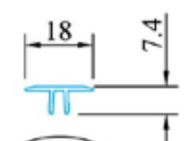

3166

W = 0.087 kg/m  
T = 1.2 mm

**MẶT DỰNG HỆ 91, ĐỘ DÀY TRUNG BÌNH 2.3 - 2.5 mm**  
**CURTAIN WALL 91, AVERAGE THICKNESS 2.3 - 2.5 mm**

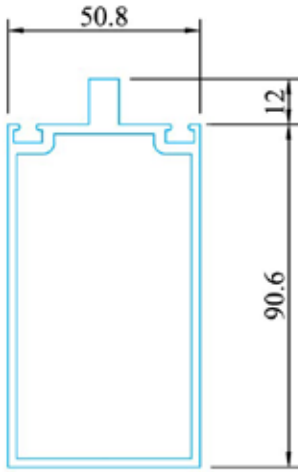

2748

W = 2.087 kg/m  
 T = 2.3 mm

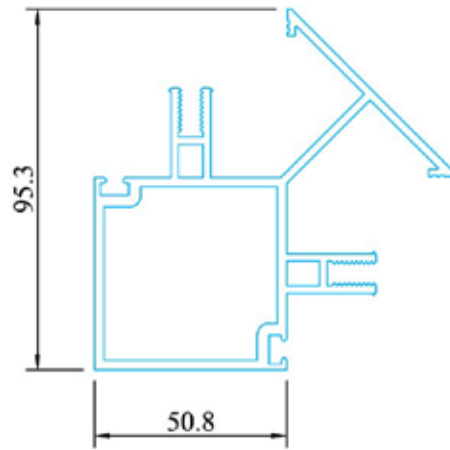

1069

W = 2.621 kg/m  
 T = 2.5 mm

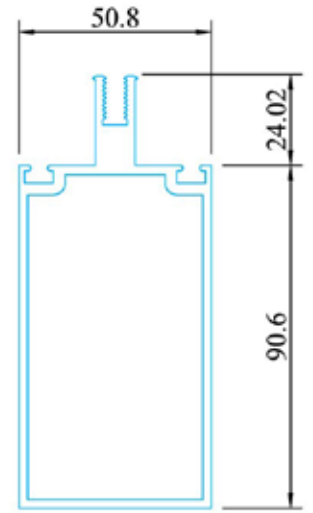

1065

W = 2.298 kg/m  
 T = 2.3 mm

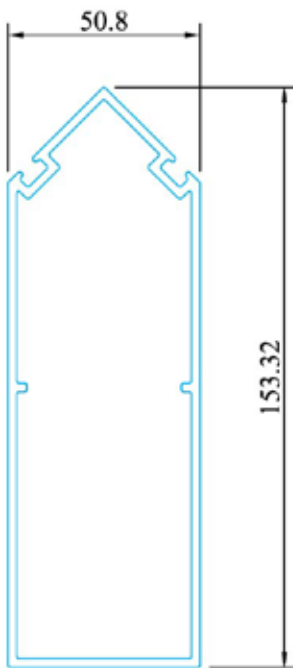

3970

W = 2.474 kg/m  
 T = 2.3 mm

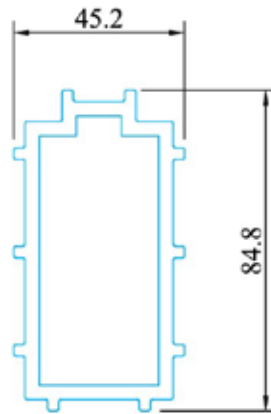

3339

W = 2.761 kg/m  
 T = 3.8 mm

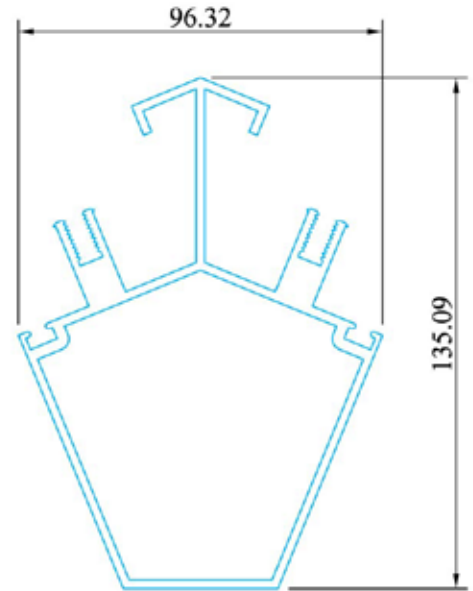

1070

W = 3.419 kg/m  
 T = 2.3 mm

1132

W = 2.508 kg/m  
 T = 3.8 mm

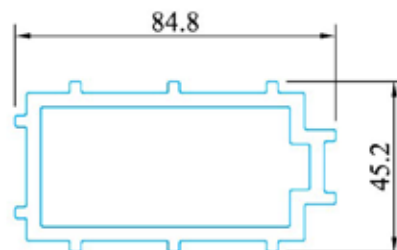

**MẶT DỰNG HỆ 91, ĐỘ DÀY TRUNG BÌNH 2.3 - 2.5 mm**  
**CURTAIN WALL 91, AVERAGE THICKNESS 2.3 - 2.5 mm**

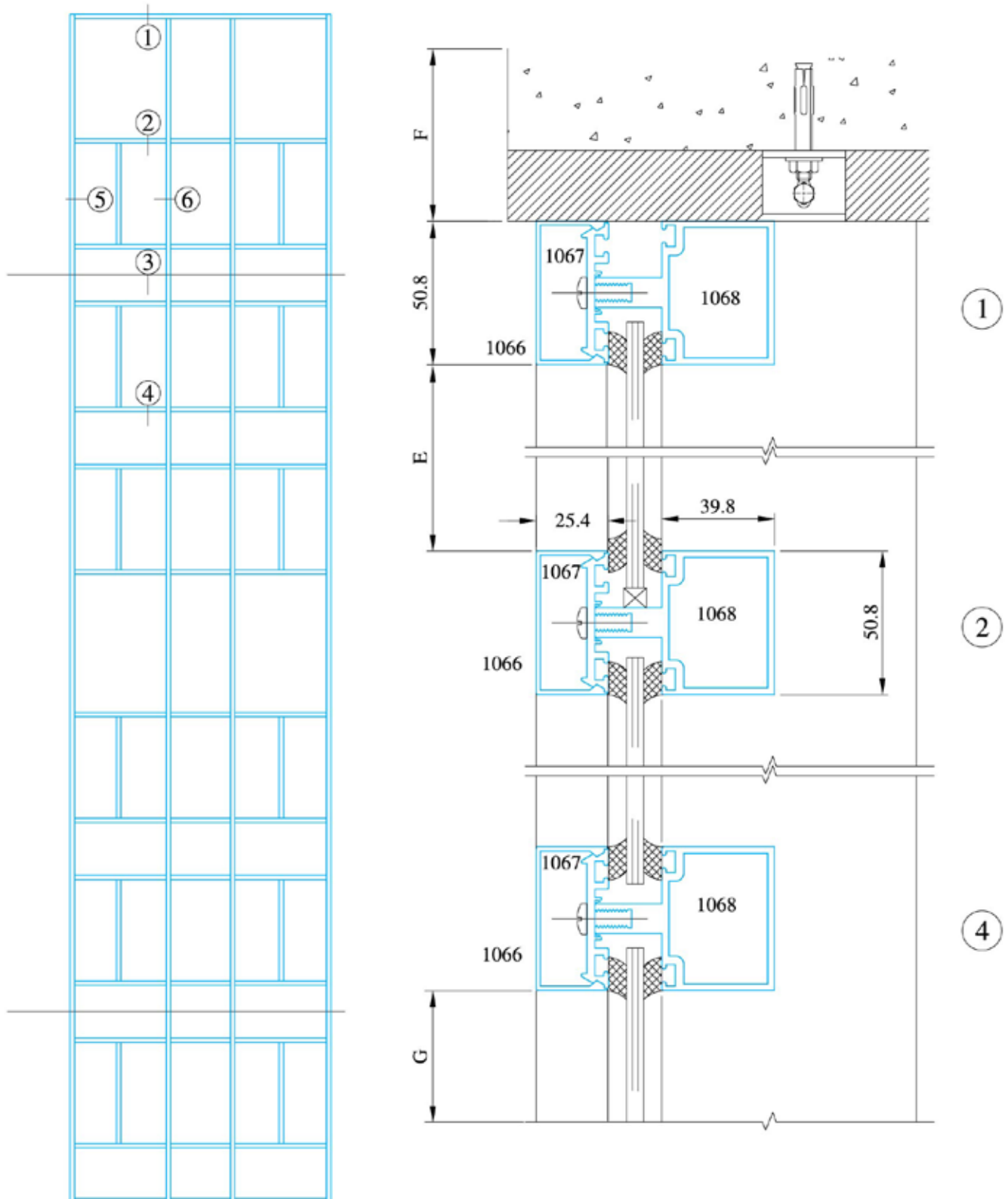

**MẶT DỰNG HỆ 91, ĐỘ DÀY TRUNG BÌNH 2.3 - 2.5 mm**  
**CURTAIN WALL 91, AVERAGE THICKNESS 2.3 - 2.5 mm**

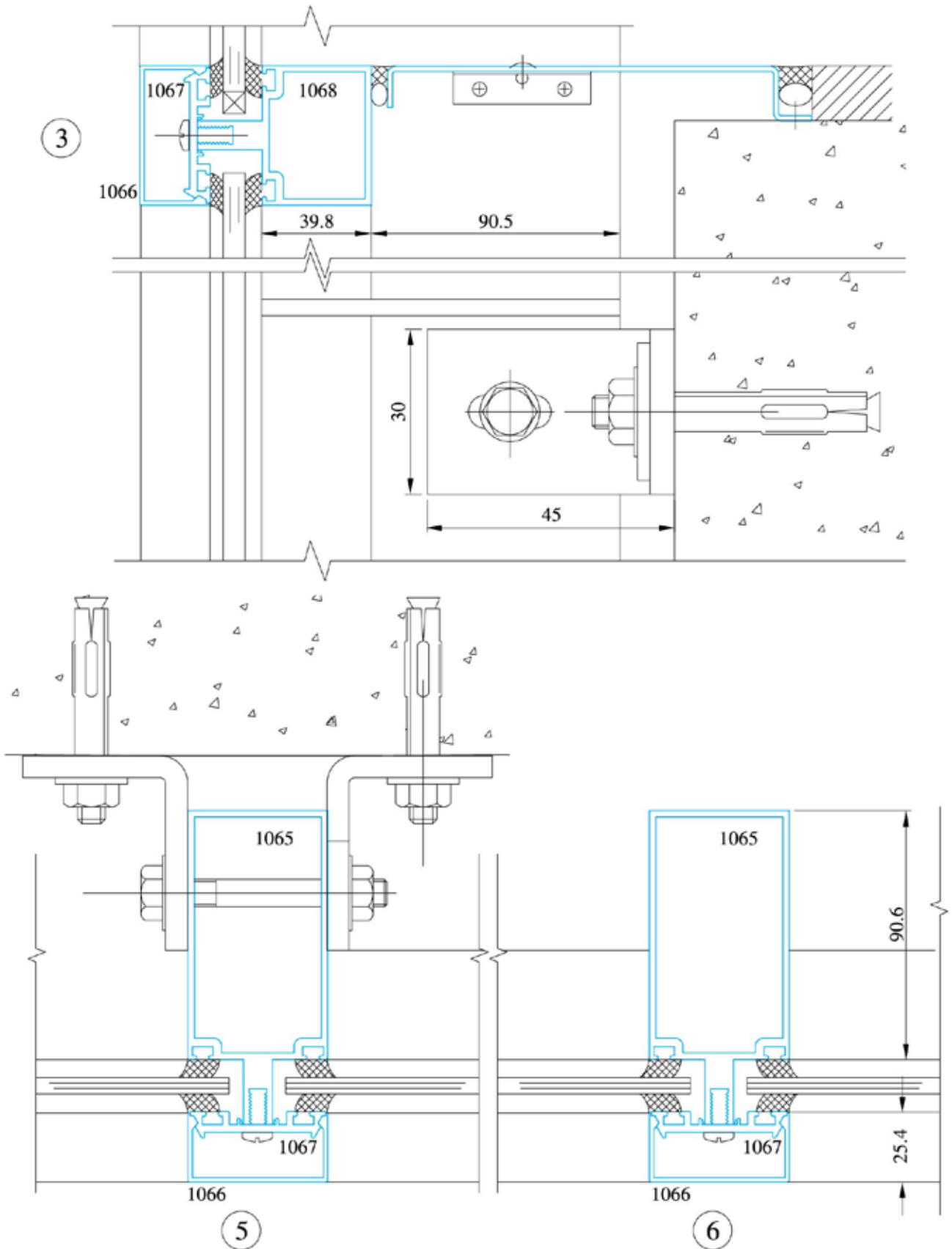

**MẶT DỰNG HỆ 91, ĐỘ DÀY TRUNG BÌNH 2.3 - 2.5 mm**  
**CURTAIN WALL 91, AVERAGE THICKNESS 2.3 - 2.5 mm**

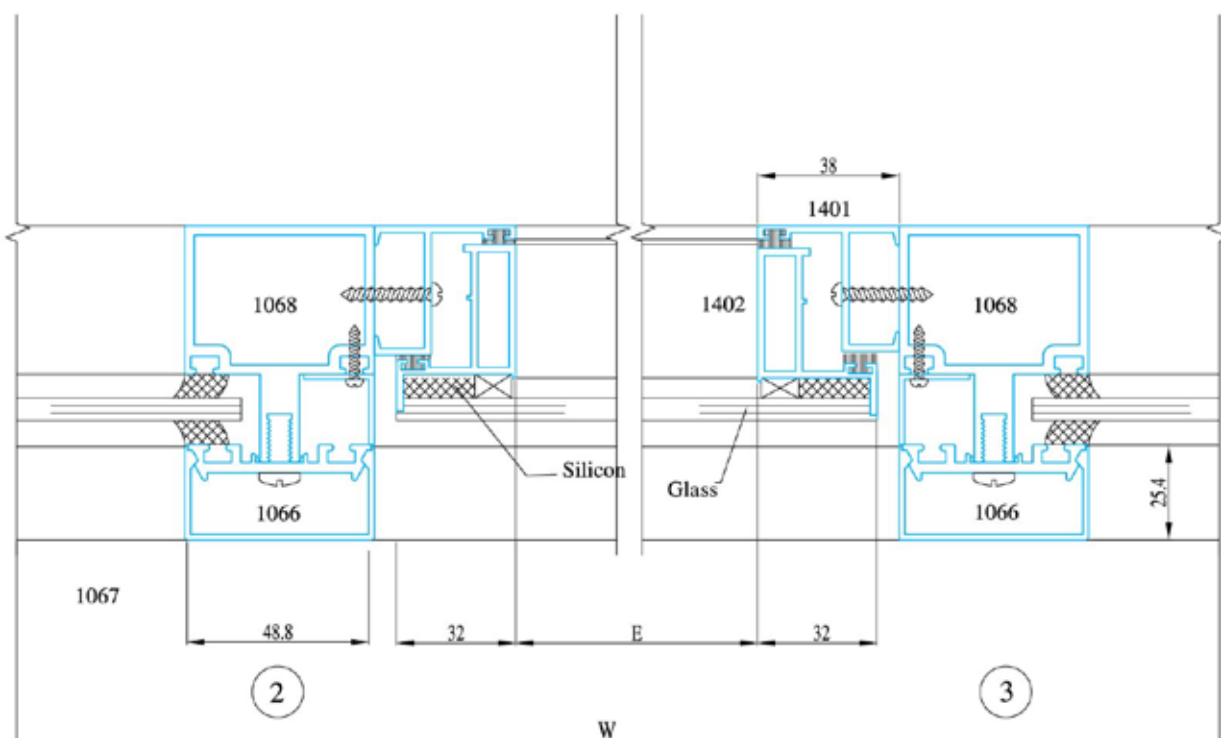
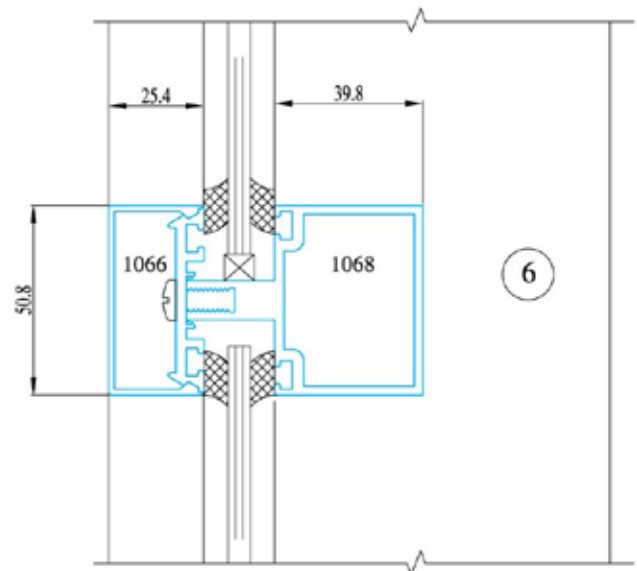
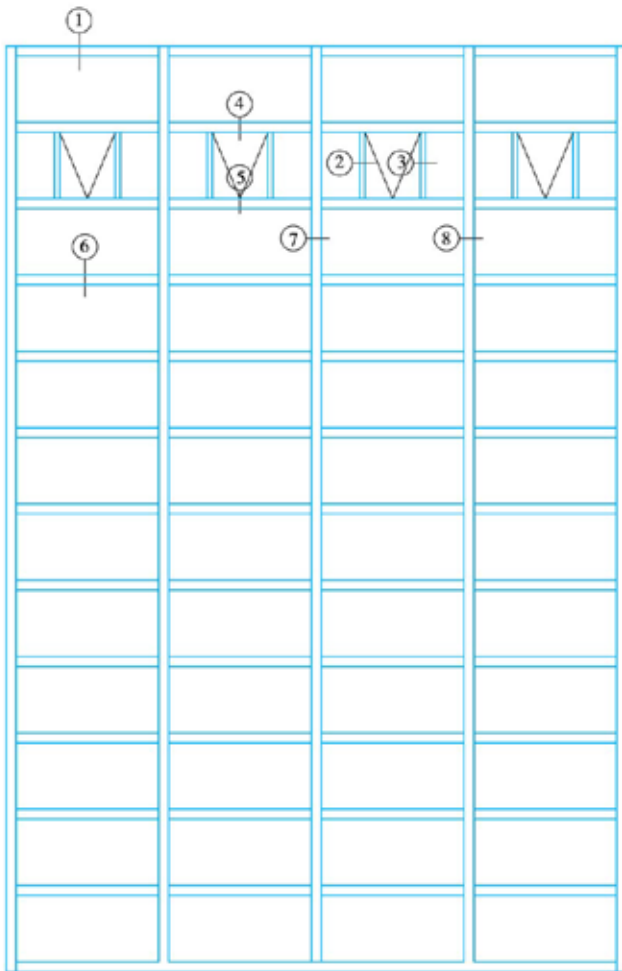

**MẶT DỰNG HỆ 91, ĐỘ DÀY TRUNG BÌNH 2.3 - 2.5 mm**  
**CURTAIN WALL 91, AVERAGE THICKNESS 2.3 - 2.5 mm**

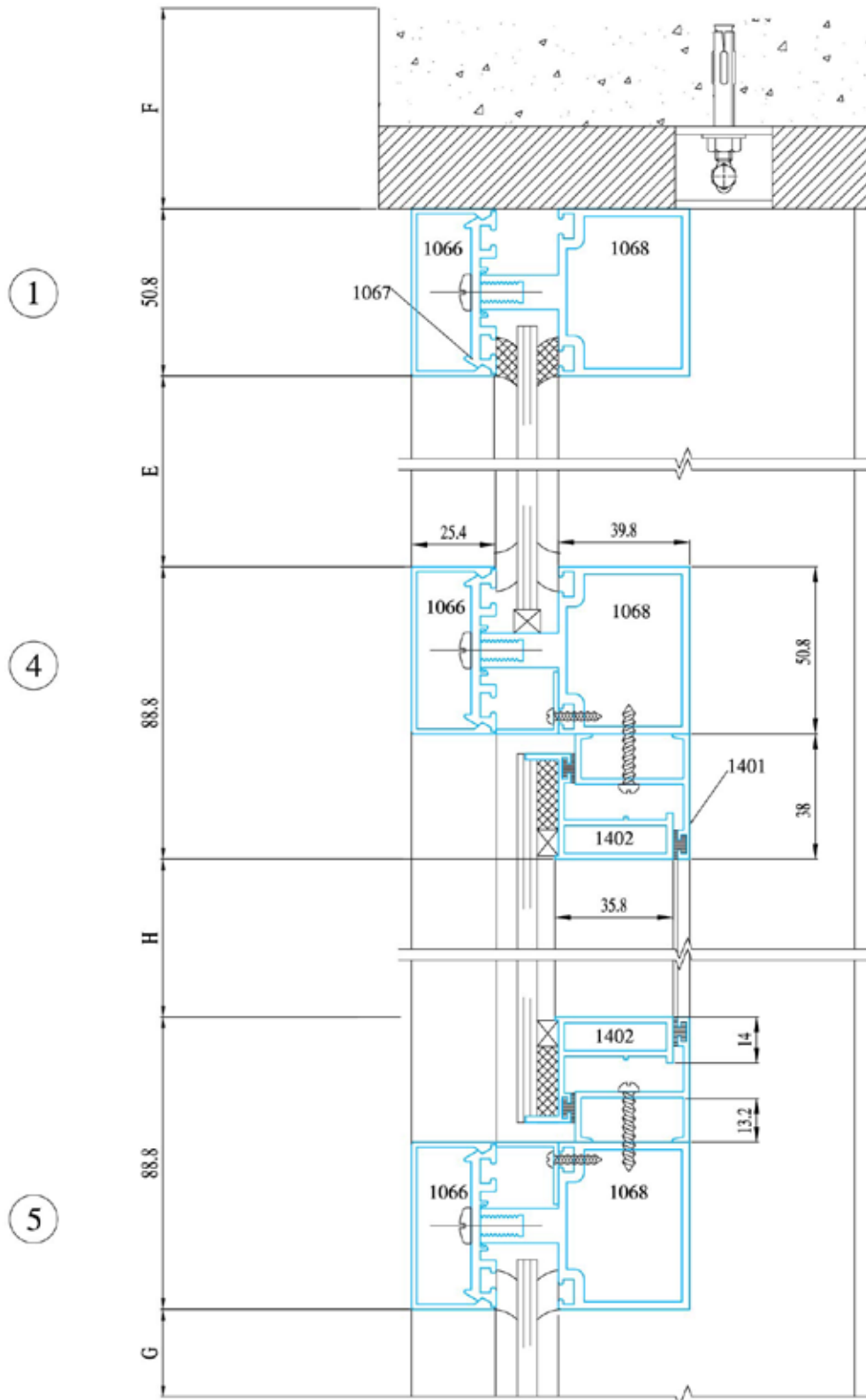

**MẶT DỰNG HỆ 91, ĐỘ DÀY TRUNG BÌNH 2.3 - 2.5 mm**  
*CURTAIN WALL 91, AVERAGE THICKNESS 2.3 - 2.5 mm*

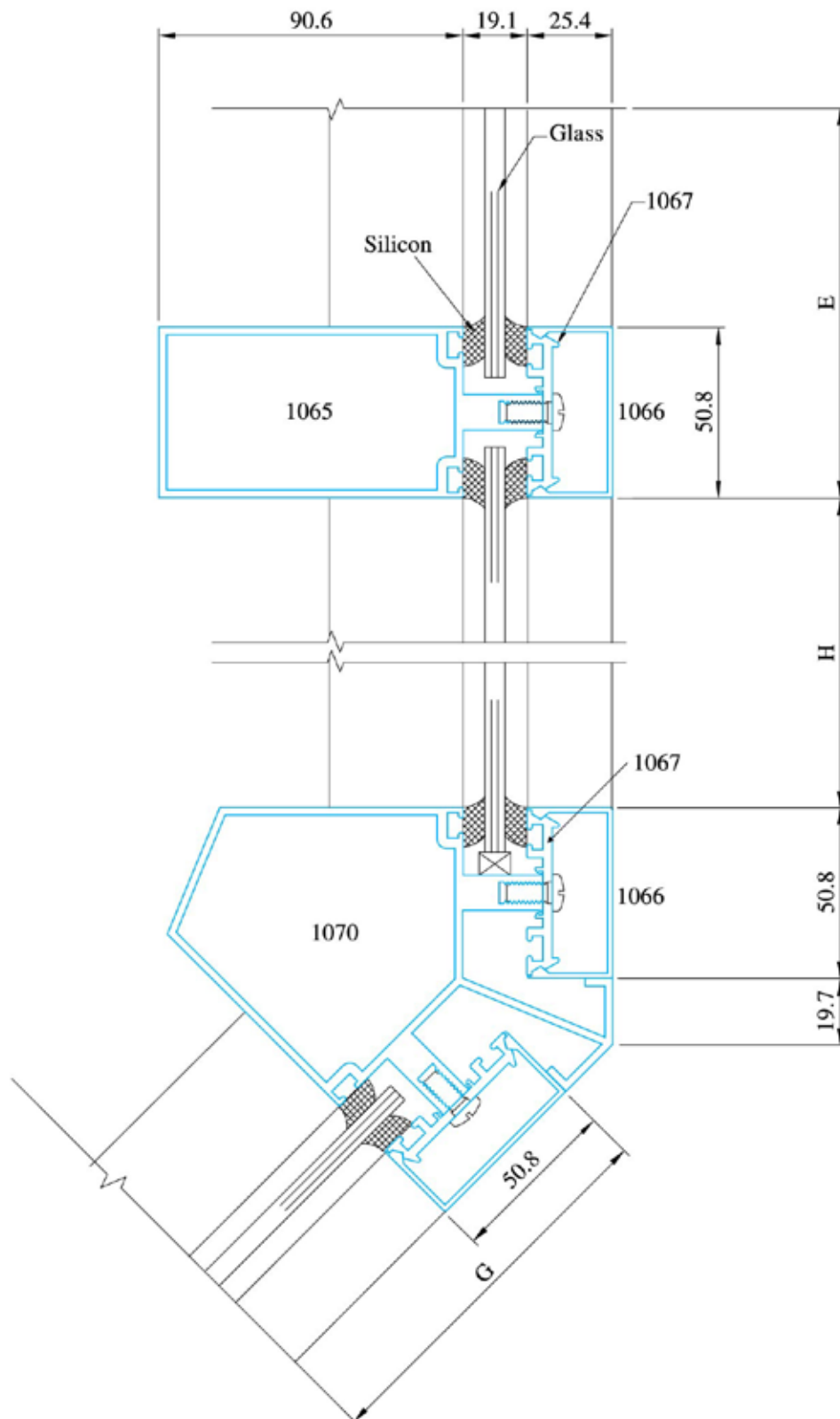

**MẶT DỰNG HỆ 91, ĐỘ DÀY TRUNG BÌNH 2.3 - 2.5 mm**  
**CURTAIN WALL 91, AVERAGE THICKNESS 2.3 - 2.5 mm**

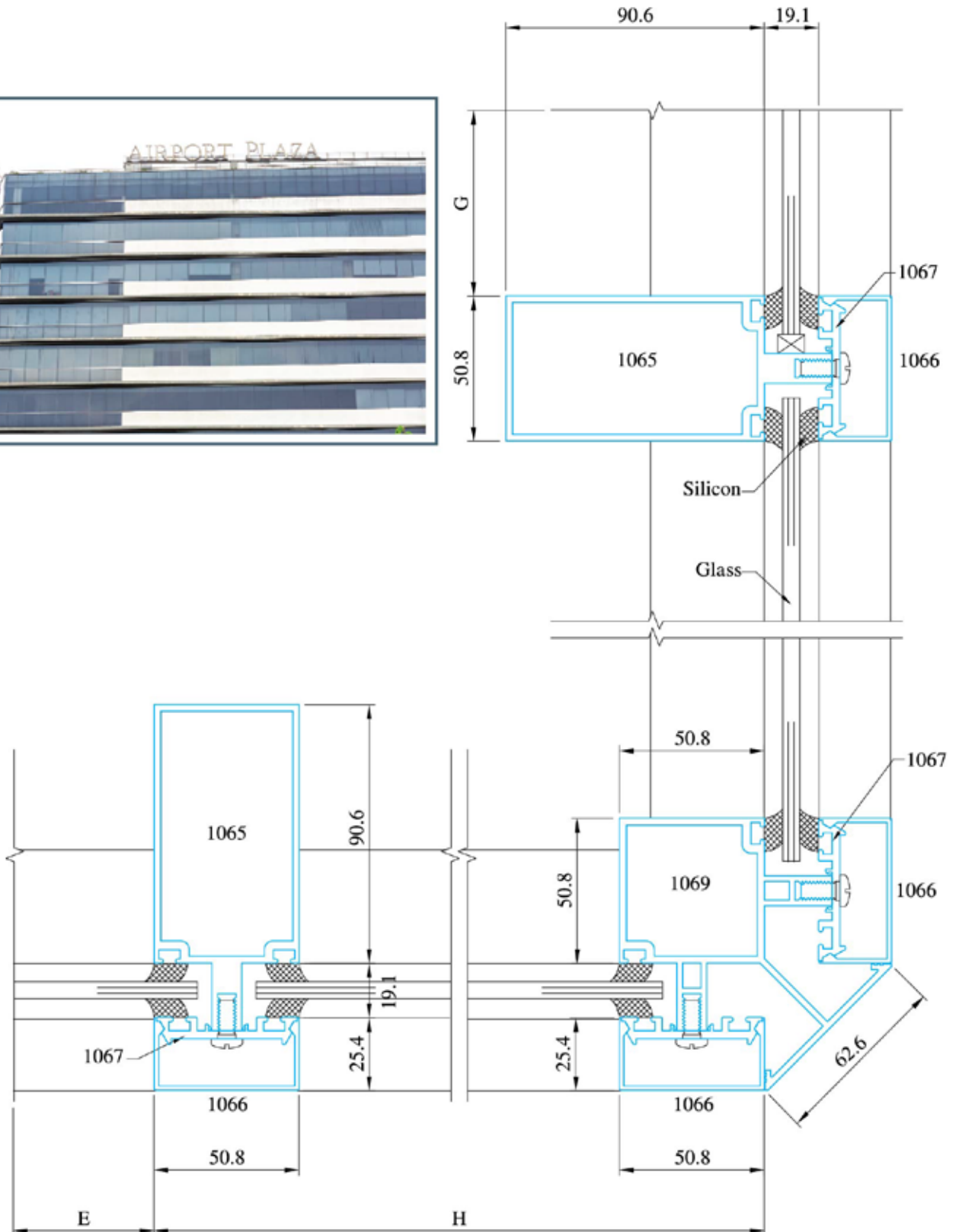

**MẶT DỰNG HỆ 91, ĐỘ DÀY TRUNG BÌNH 2.3 - 2.5 mm**  
*CURTAIN WALL 91, AVERAGE THICKNESS 2.3 - 2.5 mm*

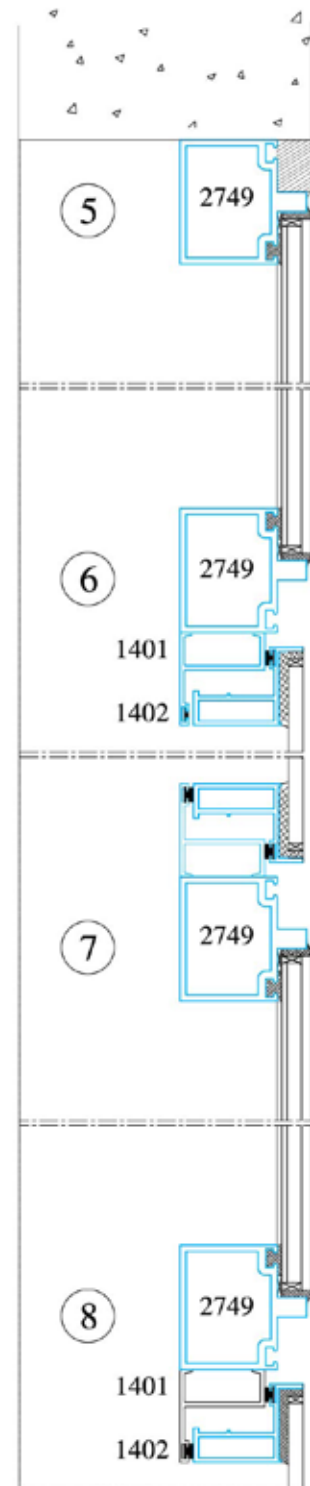
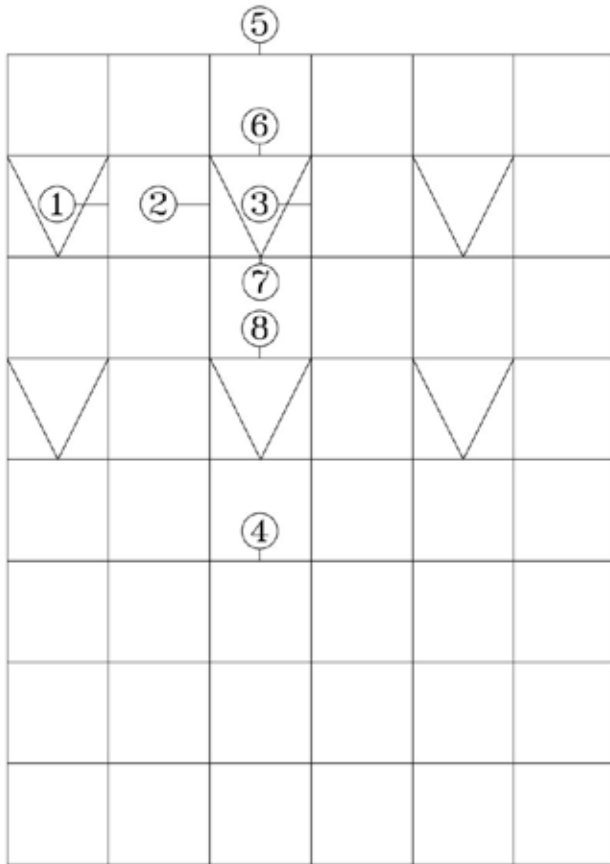

**MẶT DỰNG HỆ 91, ĐỘ DÀY TRUNG BÌNH 2.3 - 2.5 mm**  
*CURTAIN WALL 91, AVERAGE THICKNESS 2.3 - 2.5 mm*

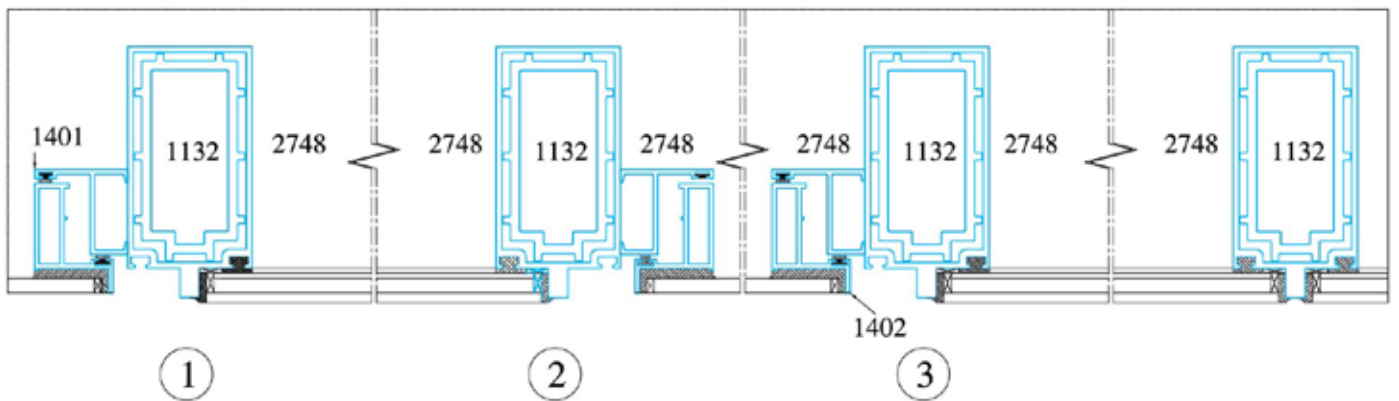
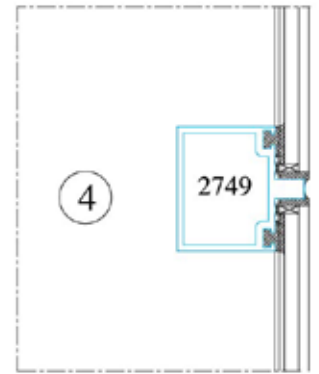

**MẶT DỰNG HỆ 91, ĐỘ DÀY TRUNG BÌNH 2.3 - 2.5 mm**  
*CURTAIN WALL 91, AVERAGE THICKNESS 2.3 - 2.5 mm*

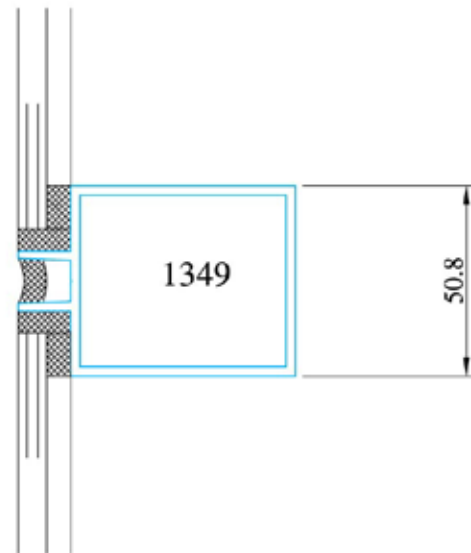
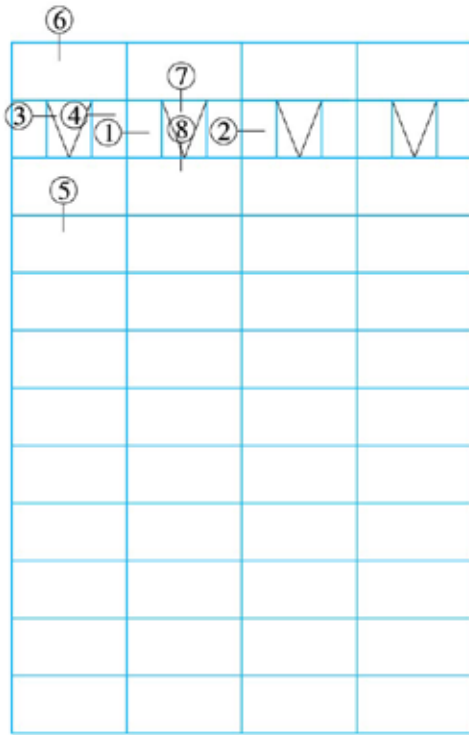

5

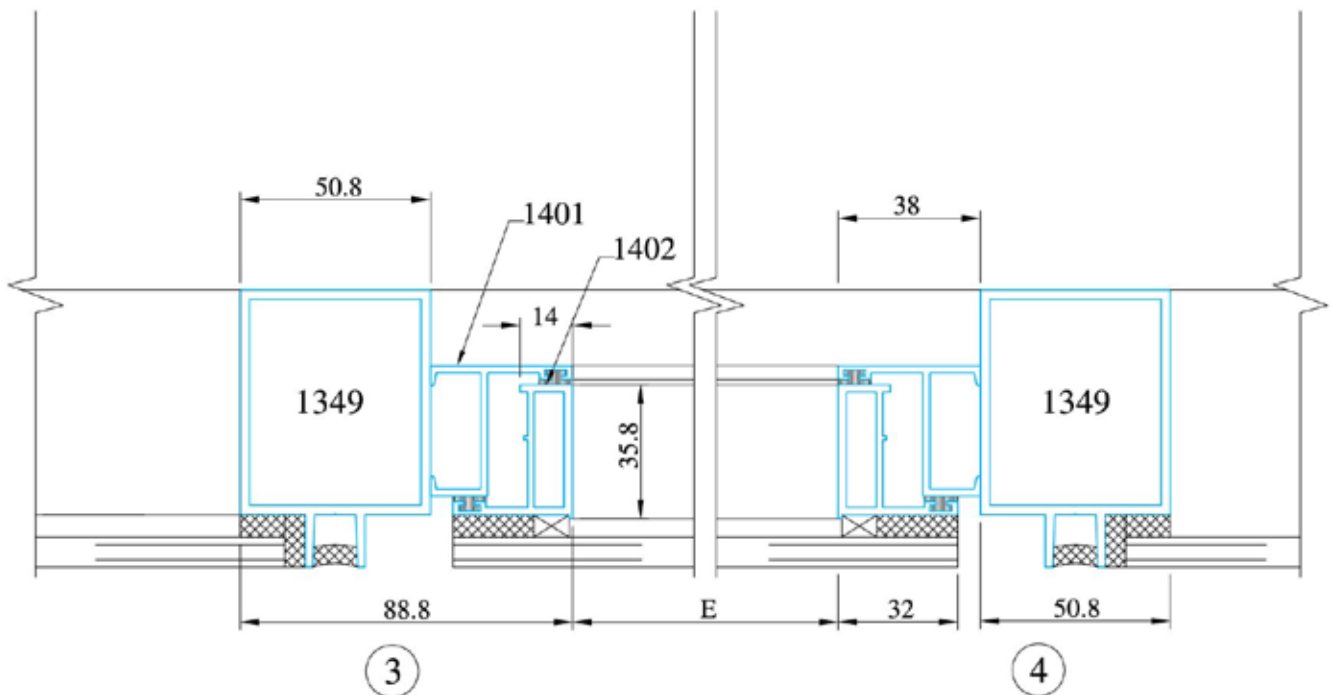

3

4

**MẶT DỰNG HỆ 91, ĐỘ DÀY TRUNG BÌNH 2.3 - 2.5 mm**  
**CURTAIN WALL 91, AVERAGE THICKNESS 2.3 - 2.5 mm**

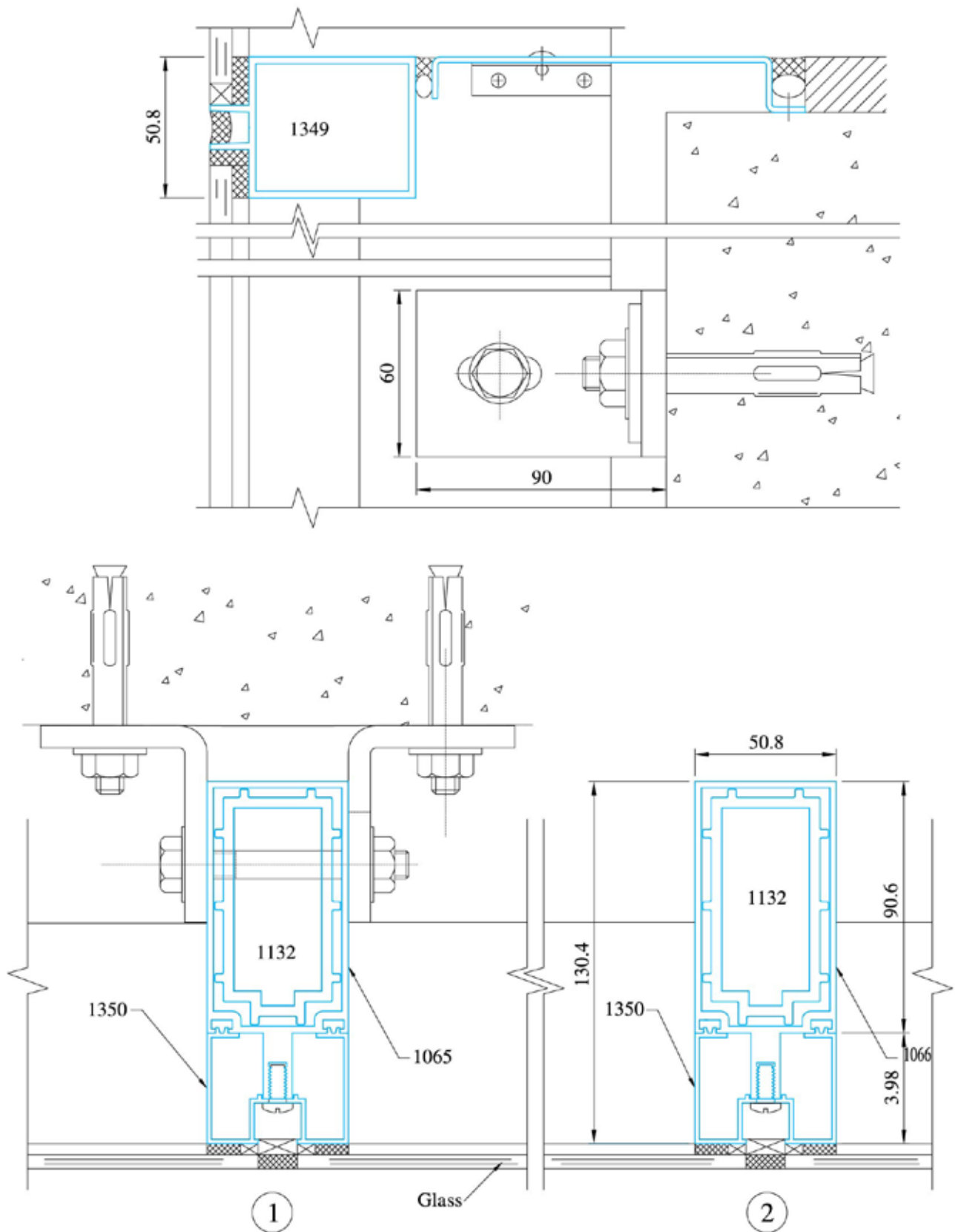

**MẶT DỰNG HỆ 108, ĐỘ DÀY TRUNG BÌNH 1.8 mm**  
**CURTAIN WALL 108, AVERAGE THICKNESS 1.8 mm**

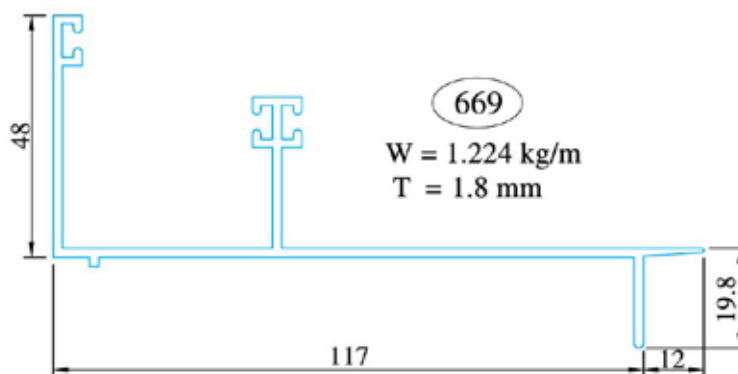
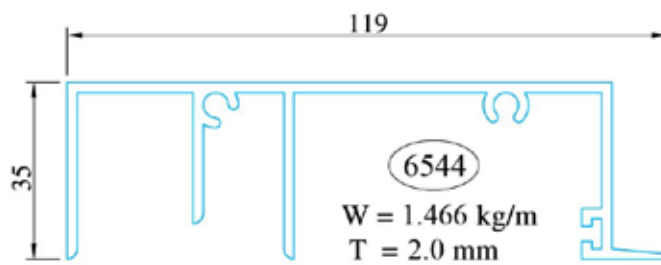
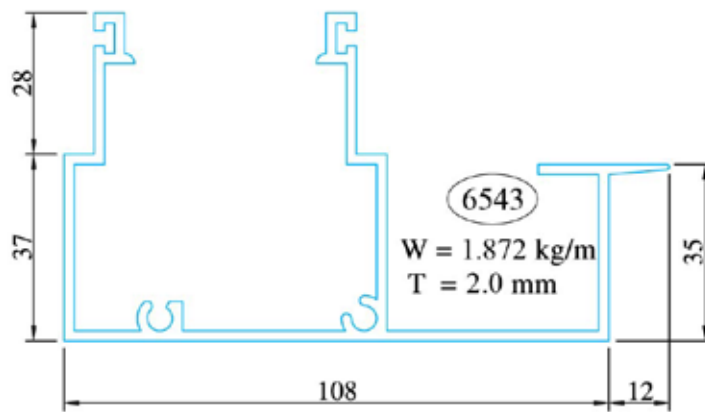
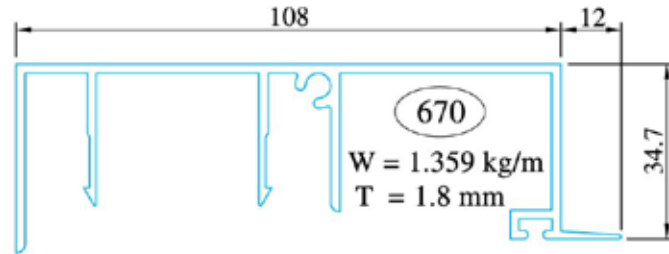

**MẶT DỰNG HỆ 108, ĐỘ DÀY TRUNG BÌNH 1.8 mm**  
**CURTAIN WALL 108, AVERAGE THICKNESS 1.8 mm**

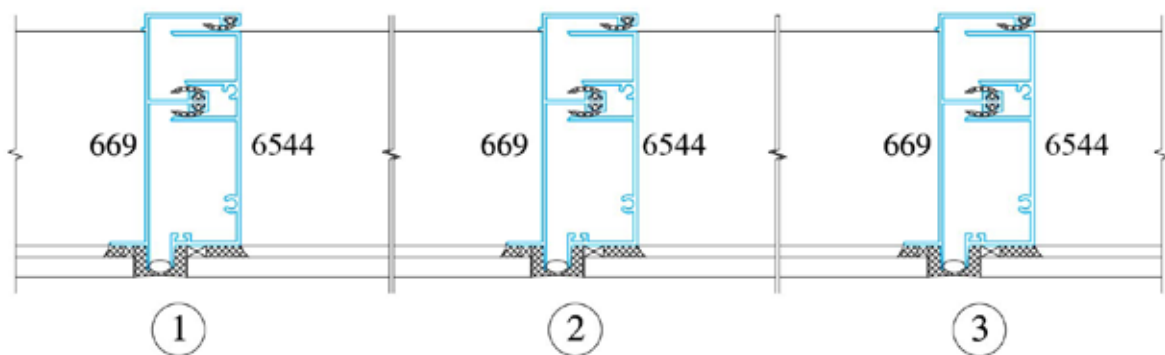
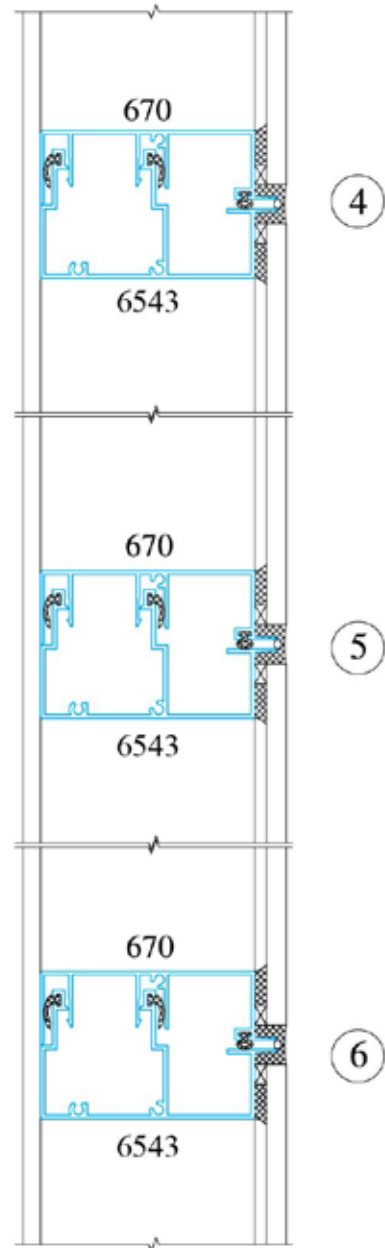
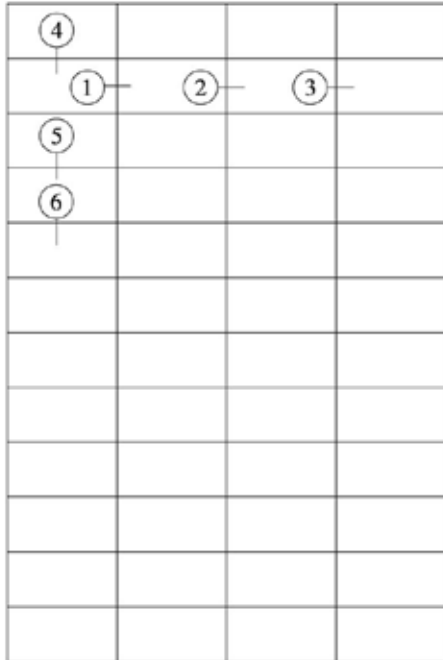

**MẶT DỰNG HỆ 110, ĐỘ DÀY TRUNG BÌNH 2.5 mm**  
**CURTAIN WALL 110, AVERAGE THICKNESS 2.5 mm**

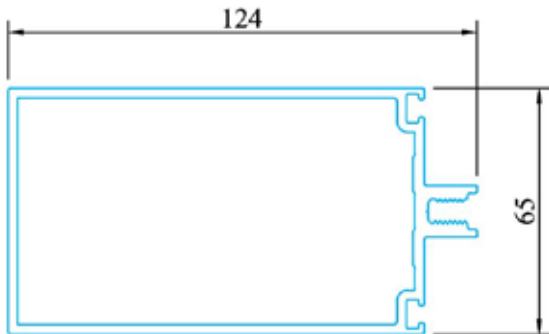

4780

W = 2.657 kg/m  
 T = 2.5 mm

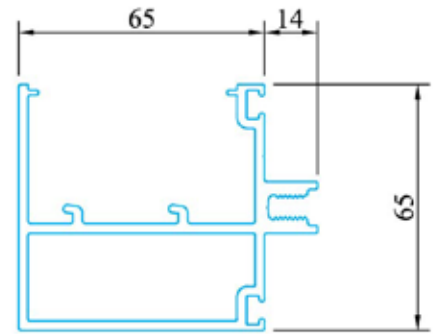

4781

W = 2.157 kg/m  
 T = 2.5 mm

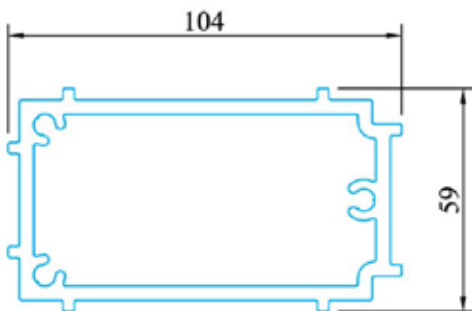

4786

W = 3.349 kg/m  
 T = 3.8 mm

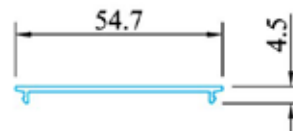

4782

W = 0.223 kg/m  
 T = 1.4 mm

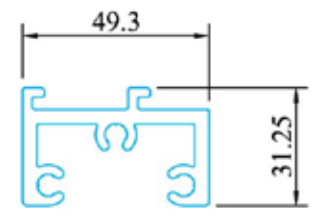

4787

W = 1.385 kg/m  
 T = 3.8 mm

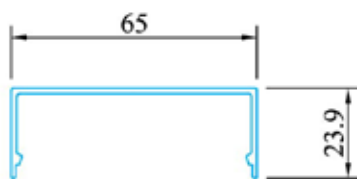

4784

W = 0.454 kg/m  
 T = 1.5 mm

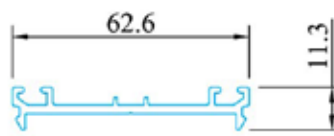

4783

W = 0.533 kg/m  
 T = 2.3 mm

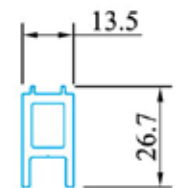

4785

W = 0.438 kg/m  
 T = 2.5 mm

**MẶT DỰNG HỆ 110, ĐỘ DÀY TRUNG BÌNH 2.5 mm**  
*CURTAIN WALL 110, AVERAGE THICKNESS 2.5 mm*

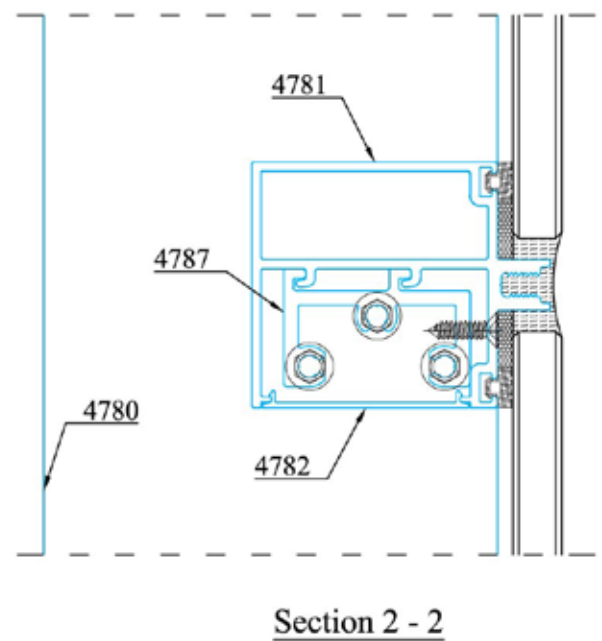
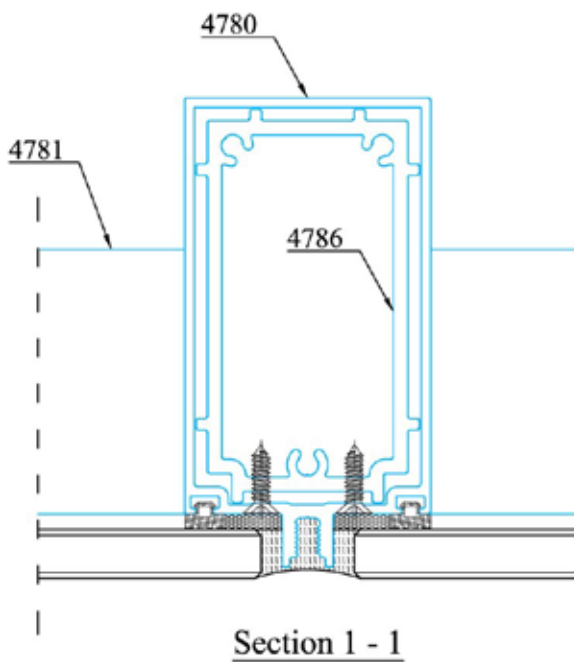
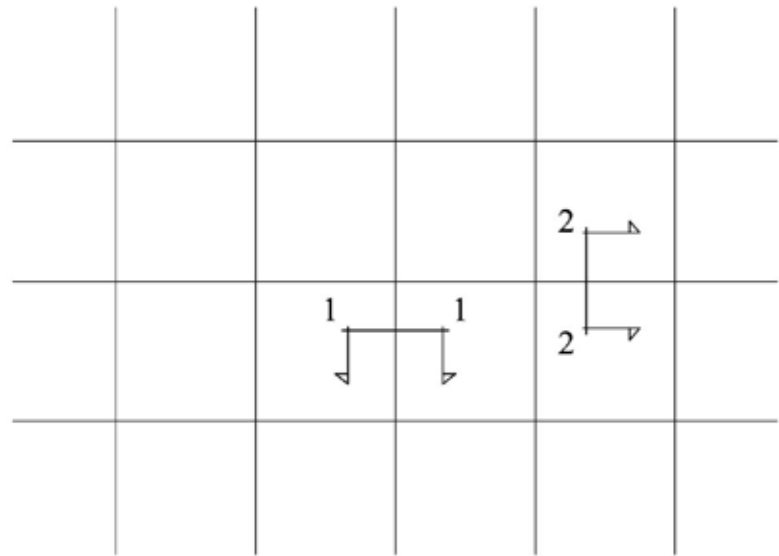

**MẶT DỰNG HỆ 110, ĐỘ DÀY TRUNG BÌNH 2.5 mm**  
*CURTAIN WALL 110, AVERAGE THICKNESS 2.5 mm*

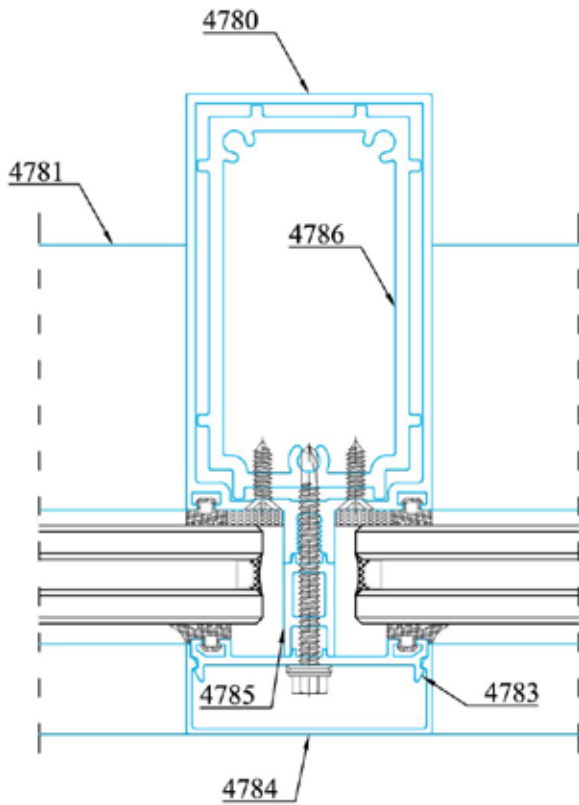

Section 1 - 1

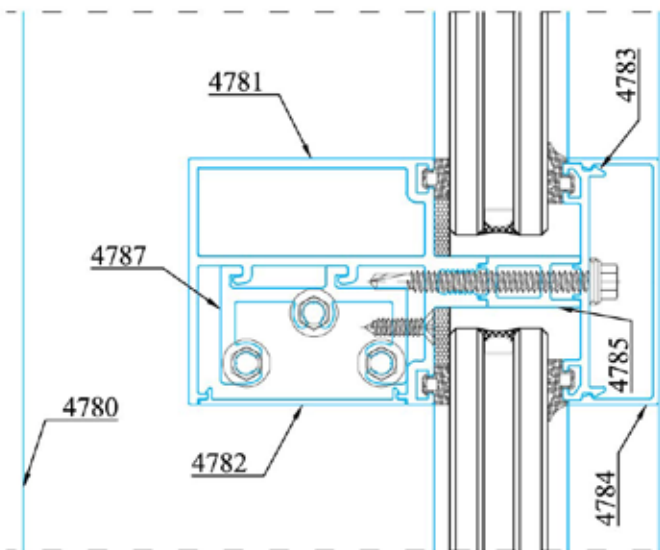
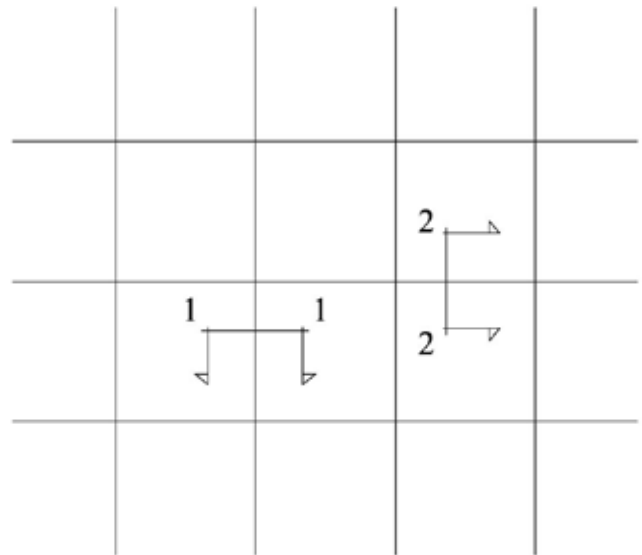

Section 2 - 2  
Option 1

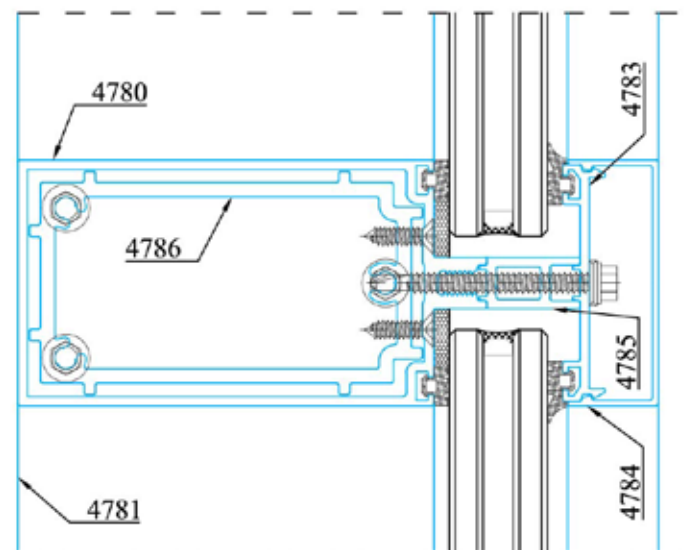

Section 2 - 2  
Option 2

**MẶT DỰNG HỆ 115, ĐỘ DÀY TRUNG BÌNH 2.0 - 3.0 mm**  
**CURTAIN WALL 115, AVERAGE THICKNESS 2.0 - 3.0 mm**

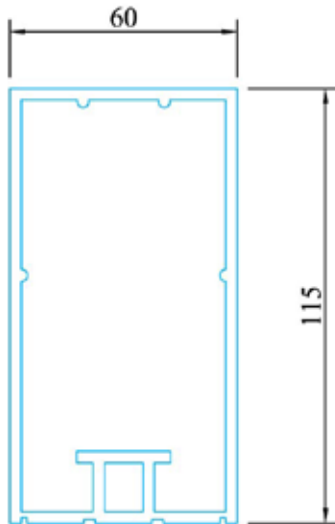

1351

W = 3.168 kg/m  
 T = 3.0 mm

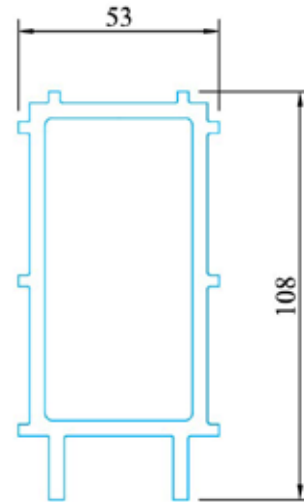

3051

W = 3.329 kg/m  
 T = 4.0 mm

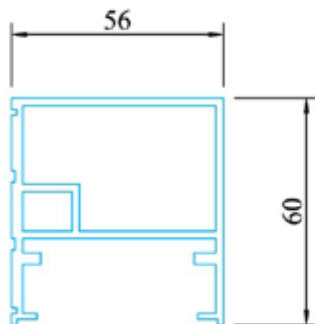

1353

W = 1.595 kg/m  
 T = 2.0 mm

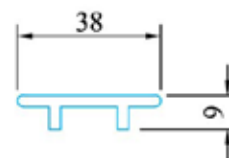

1428

W = 0.408 kg/m  
 T = 3.0 mm

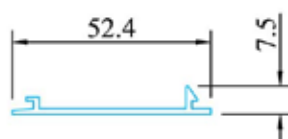

1365

W = 0.254 kg/m  
 T = 1.5 mm

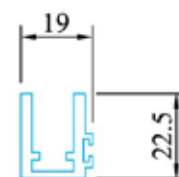

1362

W = 0.462 kg/m  
 T = 3.0 mm

**MẶT DỰNG HỆ 115, ĐỘ DÀY TRUNG BÌNH 2.0 - 3.0 mm**  
*CURTAIN WALL 115, AVERAGE THICKNESS 2.0 - 3.0 mm*

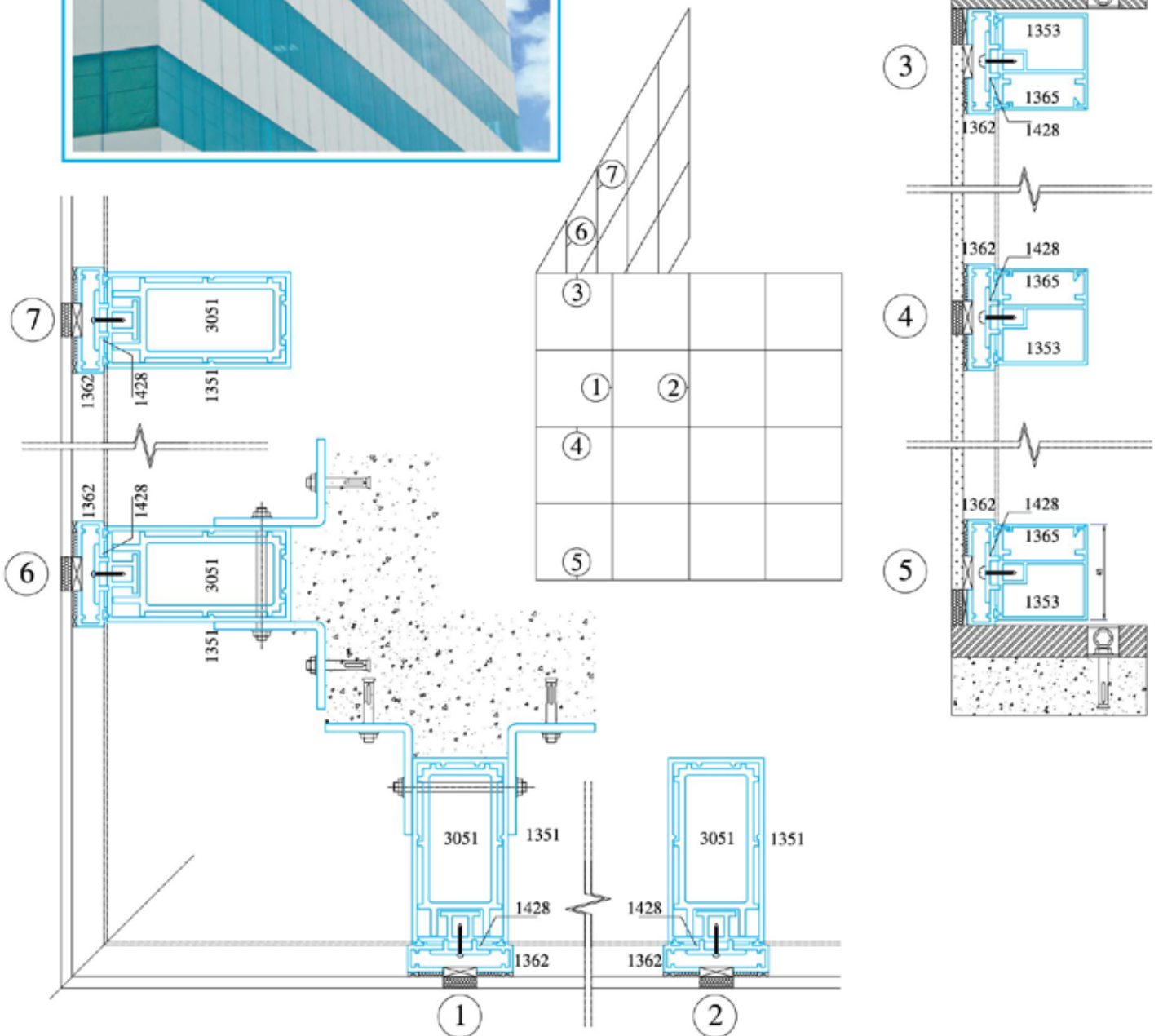
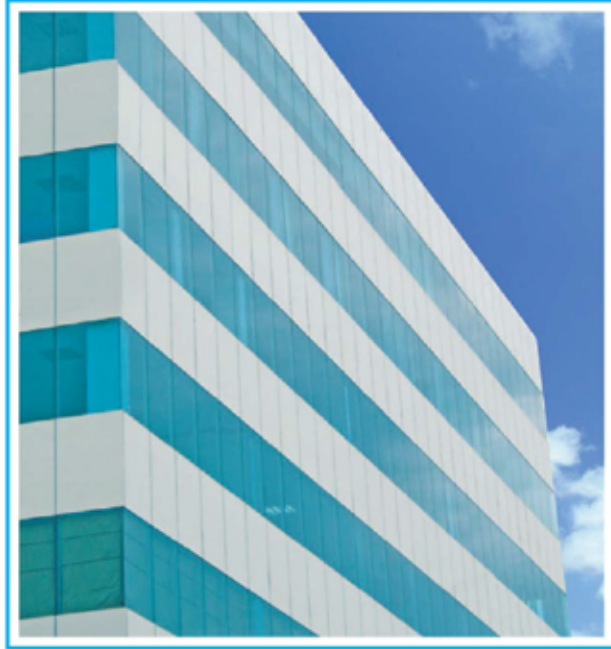

**MẶT DỰNG HỆ 115, ĐỘ DÀY TRUNG BÌNH 2.0 - 3.0 mm**  
*CURTAIN WALL 115, AVERAGE THICKNESS 2.0 - 3.0 mm*



**MẶT DỰNG HỆ 120, ĐỘ DÀY TRUNG BÌNH 2.5 mm**  
*CURTAIN WALL 120, AVERAGE THICKNESS 2.5 mm*

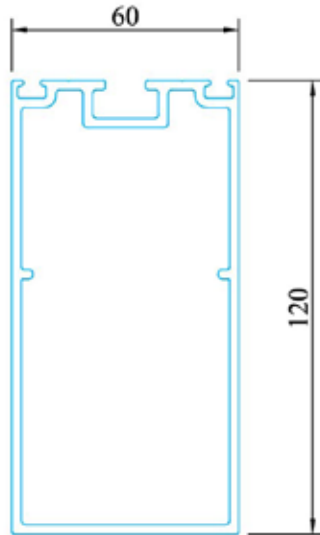

3935

W = 2.639 kg/m  
T = 2.5 mm

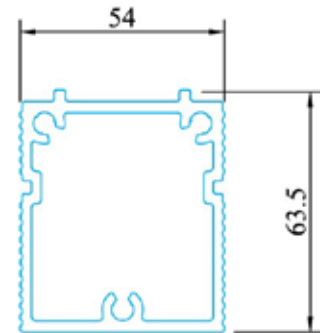

3938

W = 2.045 kg/m  
T = 2.5 mm

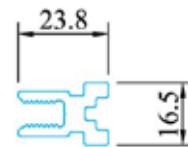

3936

W = 0.508 kg/m  
T = 2.5 mm

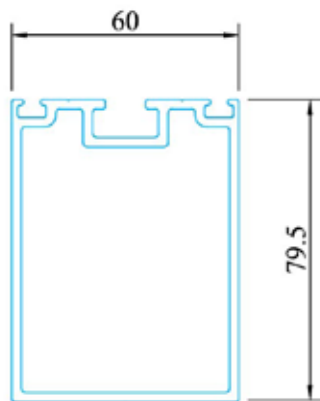

3937

W = 2.060 kg/m  
T = 2.5 mm

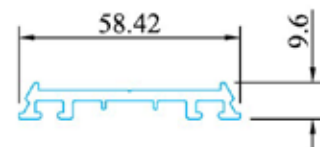

4438

W = 0.601 kg/m  
T = 2.8 mm

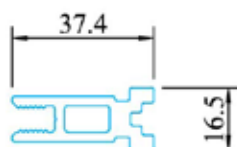

3939

W = 0.738 kg/m  
T = 2.5 mm

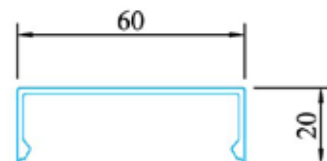

4437

W = 0.418 kg/m  
T = 1.5 mm

**MẶT DỰNG HỆ 120, ĐỘ DÀY TRUNG BÌNH 2.5 mm**  
*CURTAIN WALL 120, AVERAGE THICKNESS 2.5 mm*

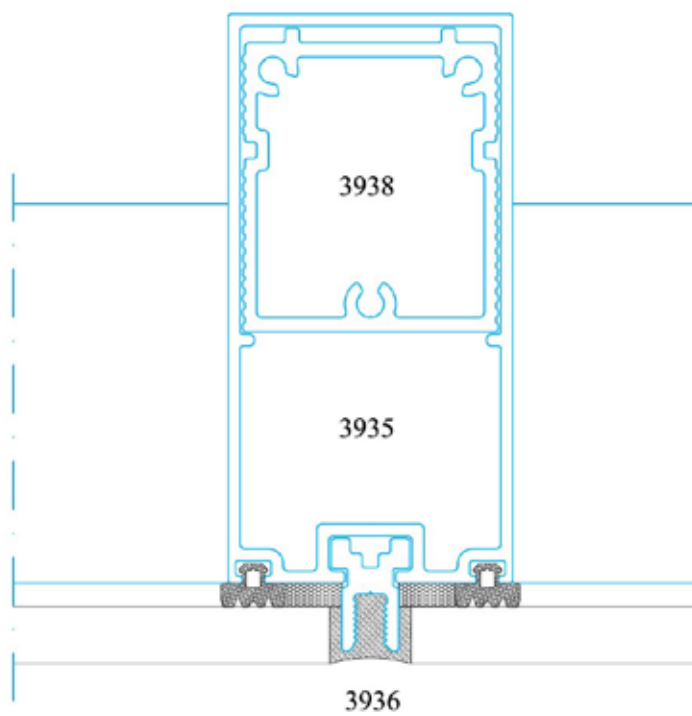
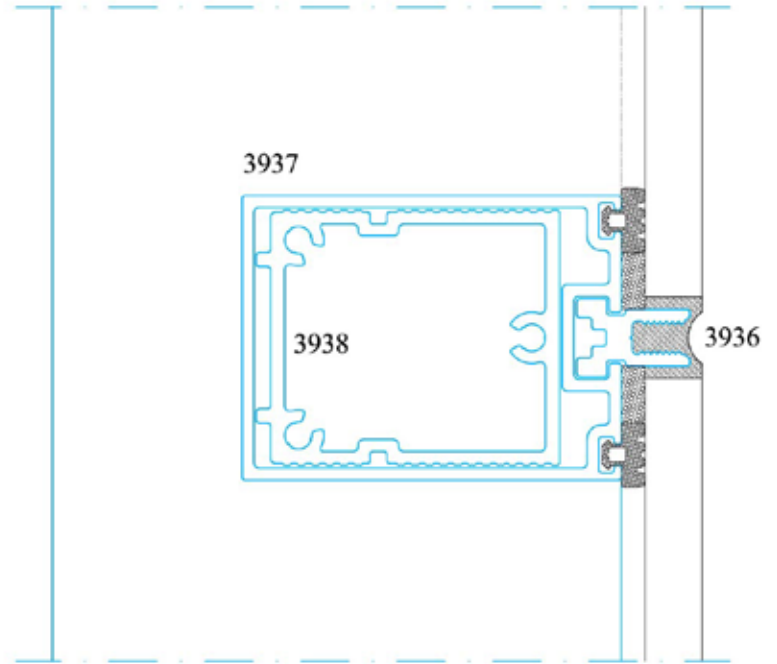
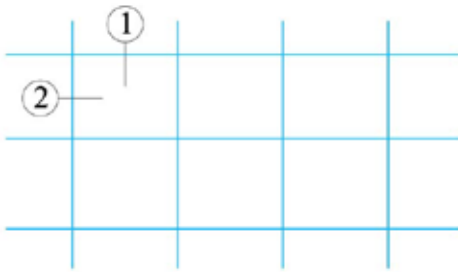

**MẶT DỰNG SEMI-UNITIZED HỆ 120, ĐỘ DÀY TRUNG BÌNH 2.0 mm**  
*SEMI-UNITIZED CURTAIN WALL 120, AVERAGE THICKNESS 2.0 mm*

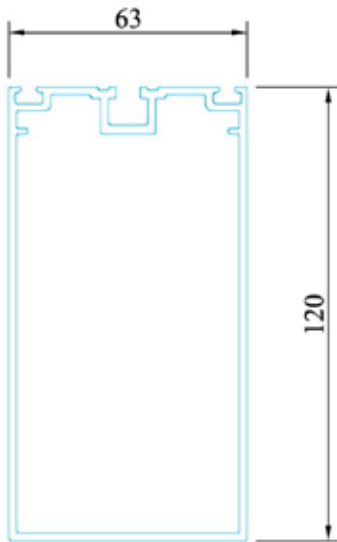

4264

W = 2.223 kg/m  
 T = 2.0 mm

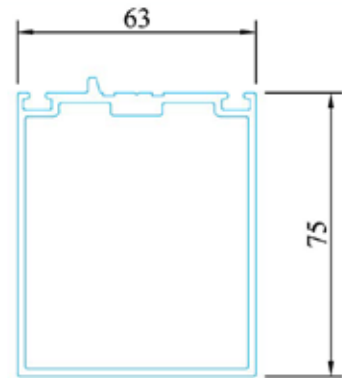

4265

W = 1.704 kg/m  
 T = 2.0 mm

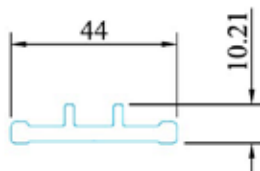

4267

W = 0.592 kg/m  
 T = 4.0 mm

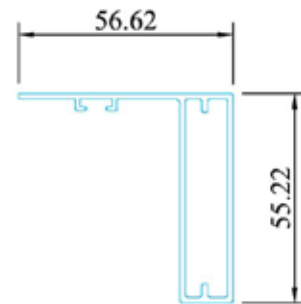

4269

W = 0.725 kg/m  
 T = 1.4 mm

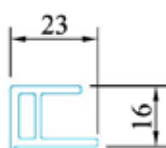

4266

W = 0.347 kg/m  
 T = 2.0 mm

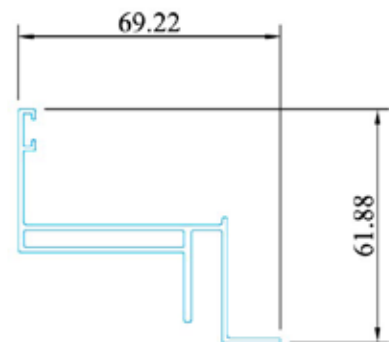

4268

W = 0.826 kg/m  
 T = 1.4 mm

**MẶT DỰNG SEMI-UNITIZED HỆ 120, ĐỘ DÀY TRUNG BÌNH 2.0 mm**  
*SEMI-UNITIZED CURTAIN WALL 120, AVERAGE THICKNESS 2.0 mm*

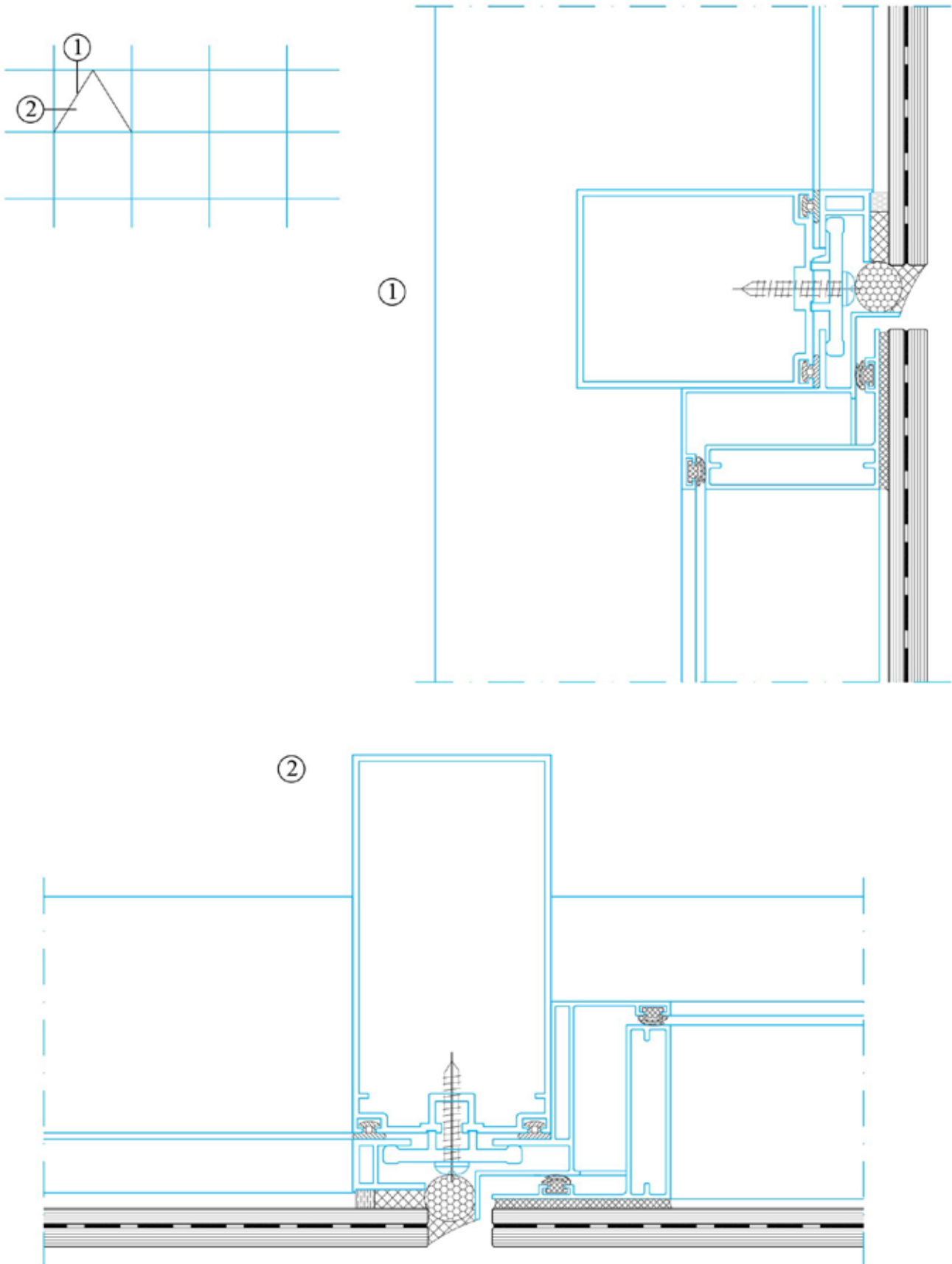

**MẶT DỰNG SEMI-UNITIZED HỆ 120, ĐỘ DÀY TRUNG BÌNH 2.0 mm**  
*SEMI-UNITIZED CURTAIN WALL 120, AVERAGE THICKNESS 2.0 mm*



**MẶT DỰNG HỆ 140, ĐỘ DÀY TRUNG BÌNH 2.5 mm**  
**CURTAIN WALL 140, AVERAGE THICKNESS 2.5 mm**

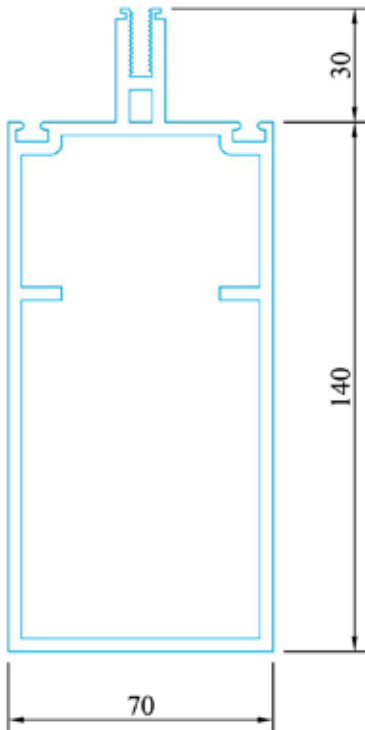

2667

W = 4.768 kg/m  
T = 3.5 mm

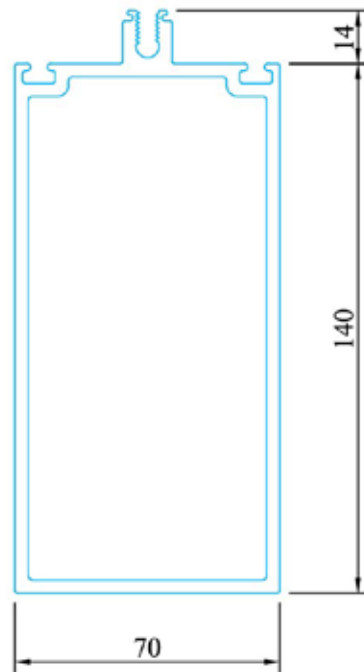

3732

W = 4.215 kg/m  
T = 3.5 mm

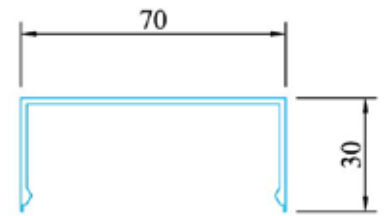

2670

W = 0.551 kg/m  
T = 1.6 mm

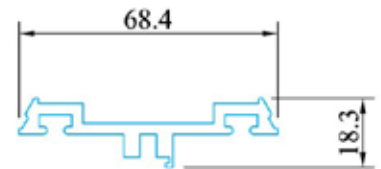

2669

W = 0.915 kg/m  
T = 3.0 mm

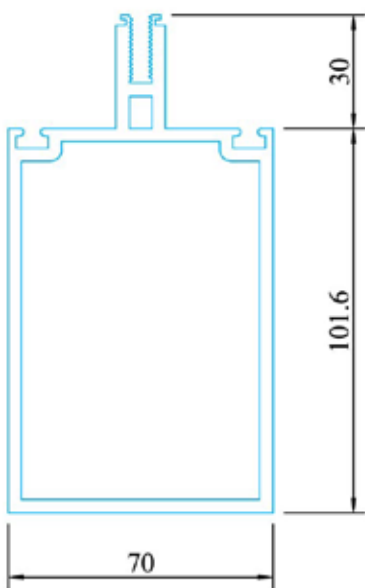

2668

W = 3.833 kg/m  
T = 3.5 mm

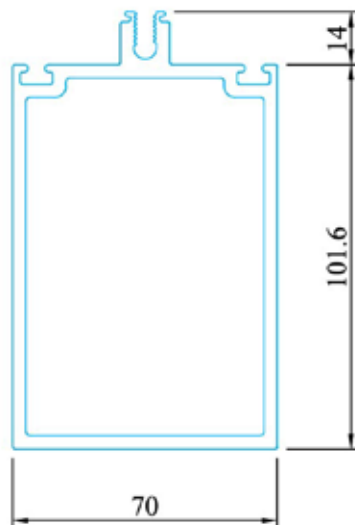

3731

W = 3.490 kg/m  
T = 3.5 mm

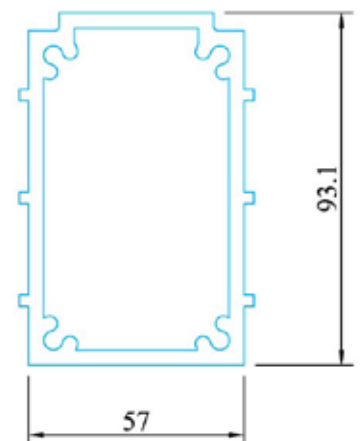

2671

W = 3.502 kg/m  
T = 4.0 mm

**MẶT DỰNG HỆ 140, ĐỘ DÀY TRUNG BÌNH 2.5 mm**  
**CURTAIN WALL 140, AVERAGE THICKNESS 2.5 mm**

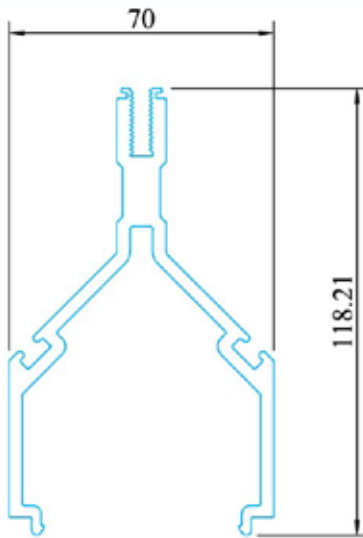

5566

W = 2.921 kg/m  
T = 3.5 mm

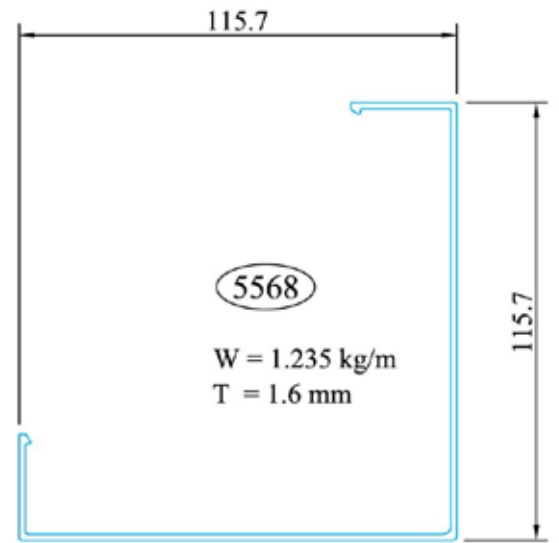

5568

W = 1.235 kg/m  
T = 1.6 mm

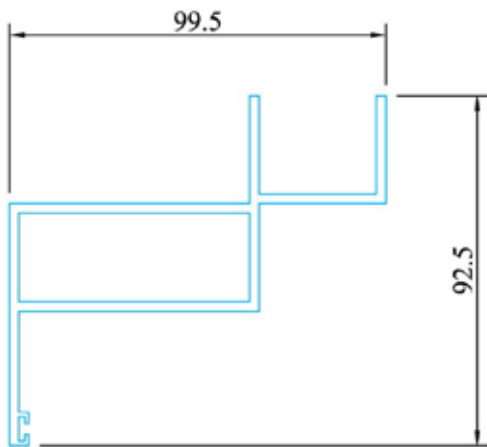

2673

W = 2.074 kg/m  
T = 2.5 mm

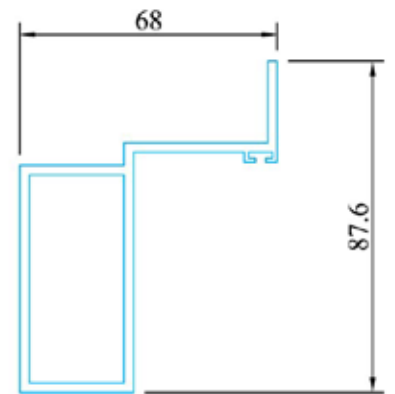

2672

W = 1.623 kg/m  
T = 2.5 mm

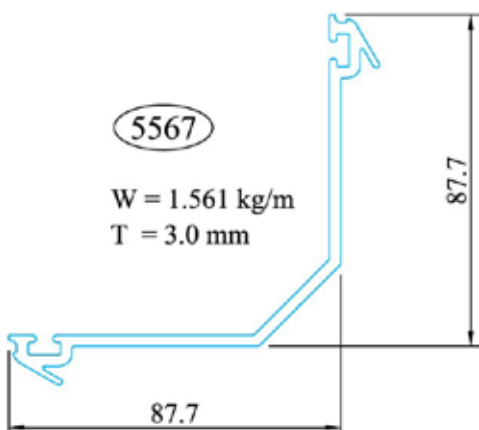

5567

W = 1.561 kg/m  
T = 3.0 mm

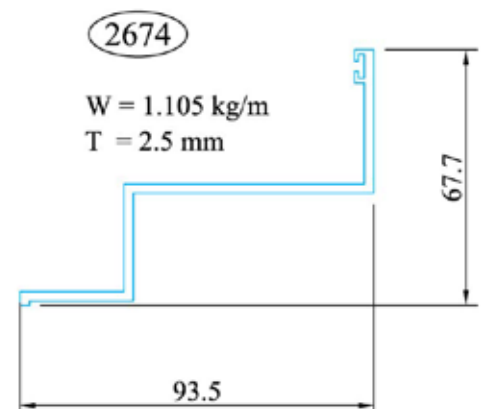

2674

W = 1.105 kg/m  
T = 2.5 mm

**MẶT DỰNG HỆ 140, ĐỘ DÀY TRUNG BÌNH 2.5 mm**  
*CURTAIN WALL 140, AVERAGE THICKNESS 2.5 mm*

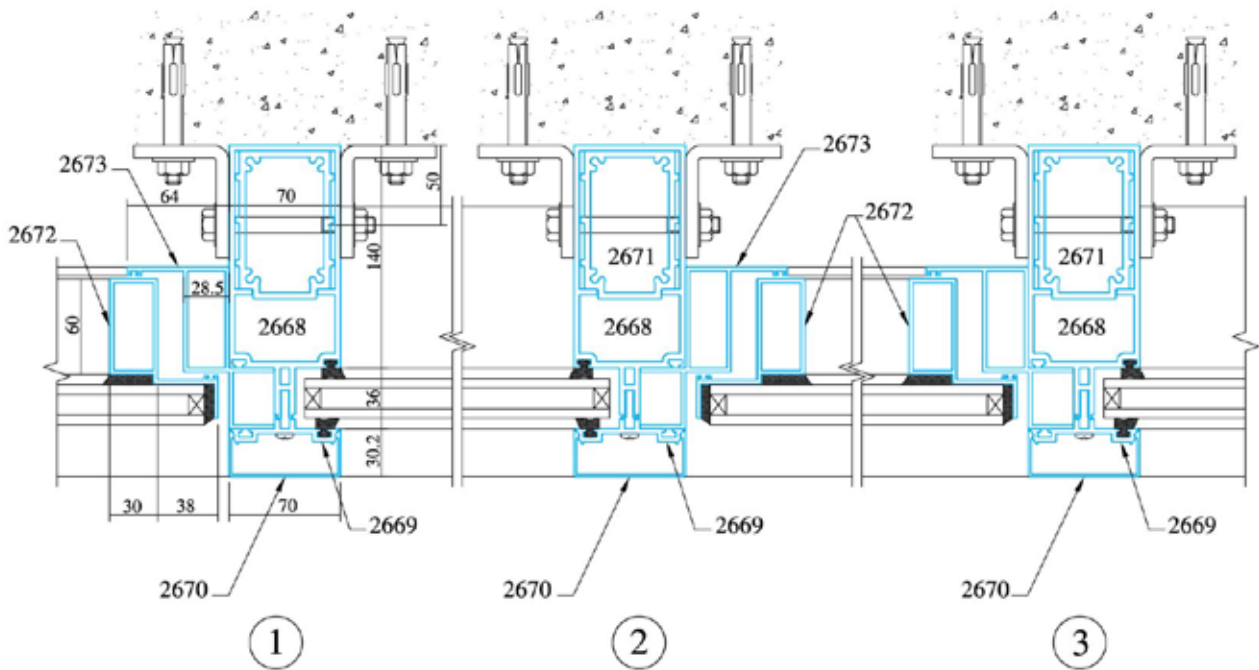
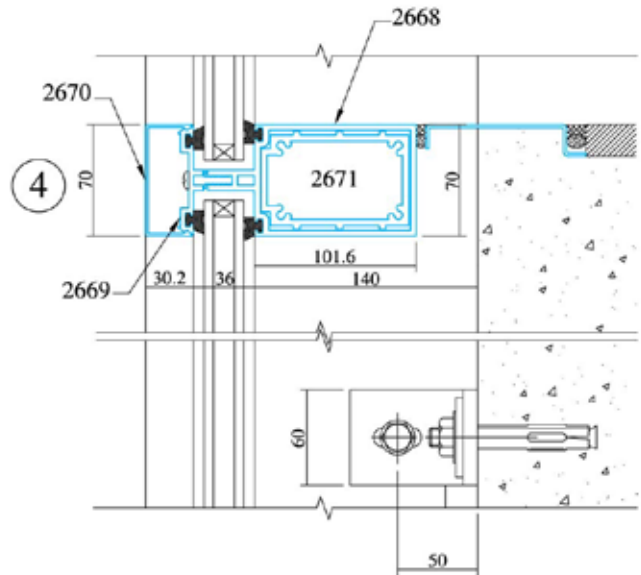
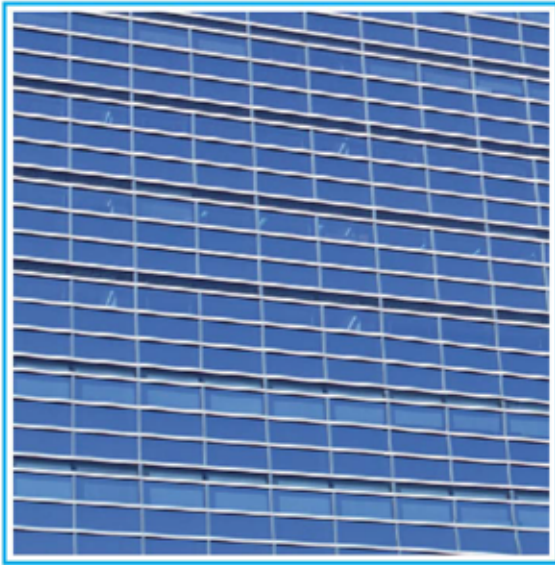

**MẶT DỰNG HỆ 140, ĐỘ DÀY TRUNG BÌNH 2.5 mm**  
*CURTAIN WALL 140, AVERAGE THICKNESS 2.5 mm*

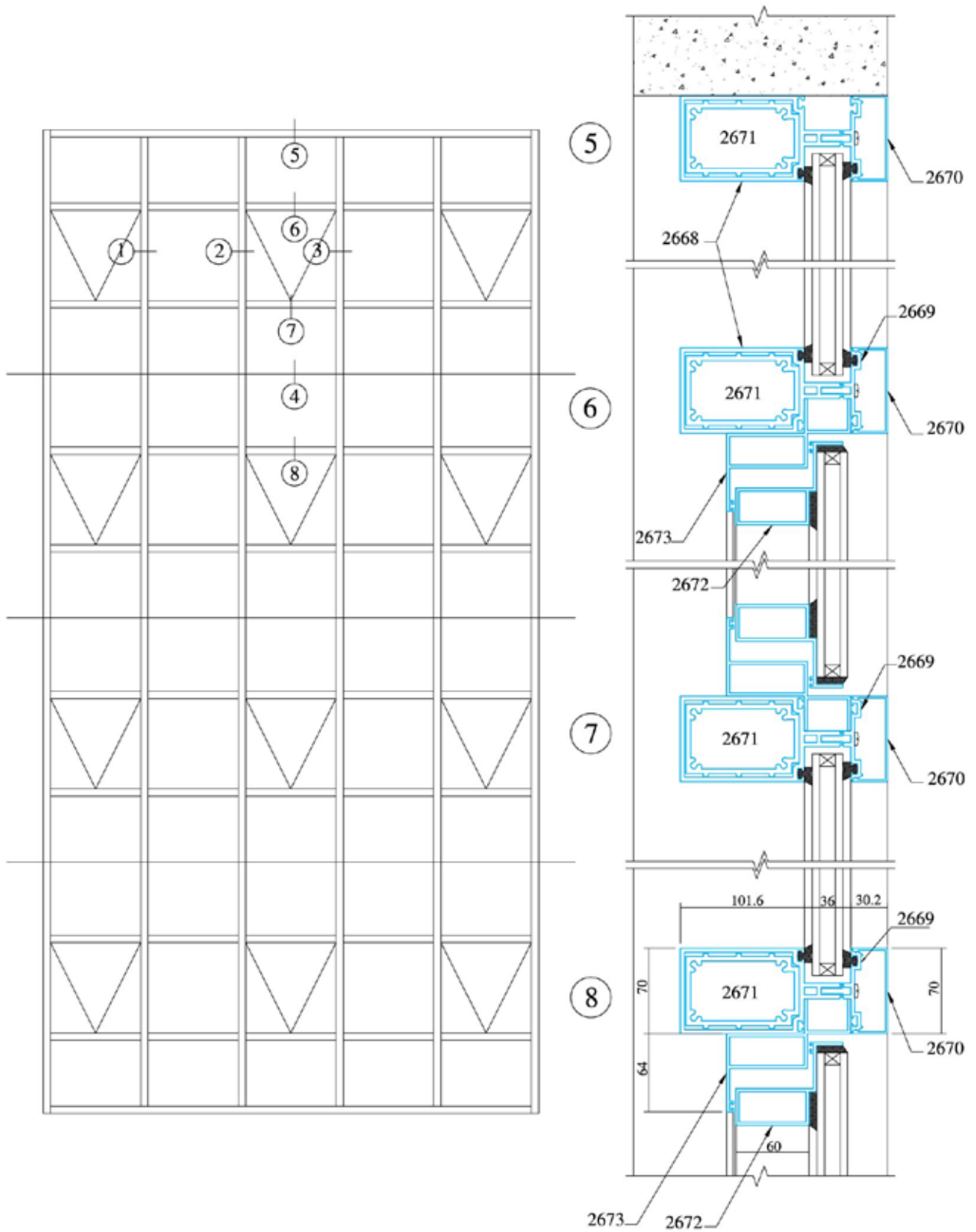

**MẶT DỰNG HỆ 140, ĐỘ DÀY TRUNG BÌNH 2.5 mm**  
*CURTAIN WALL 140, AVERAGE THICKNESS 2.5 mm*

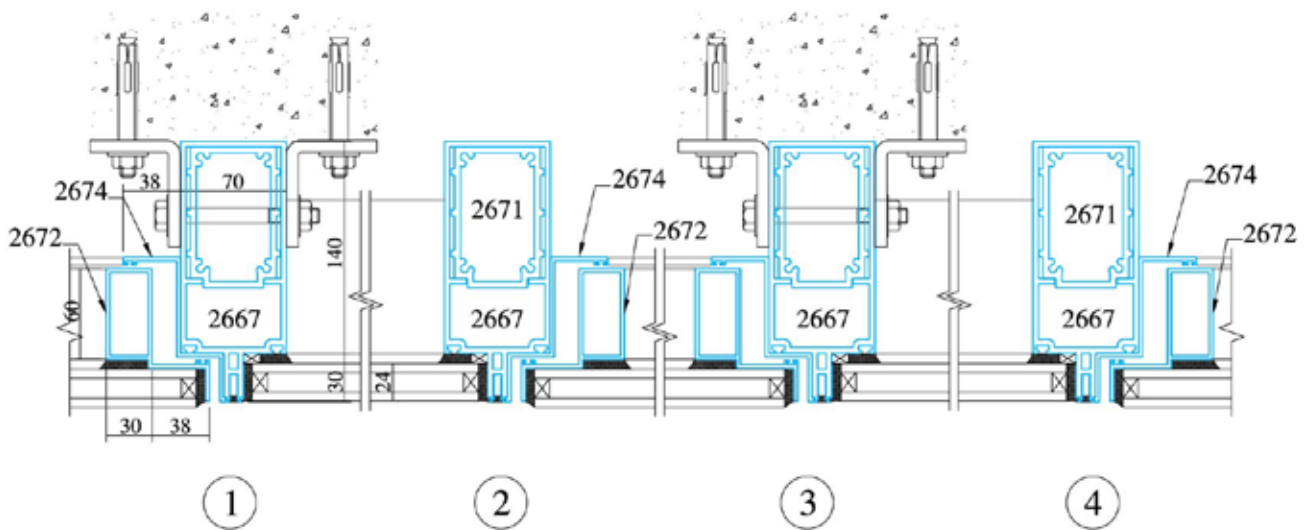
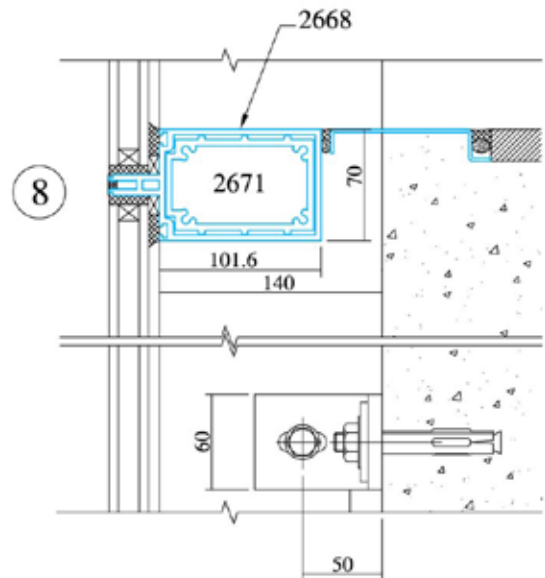
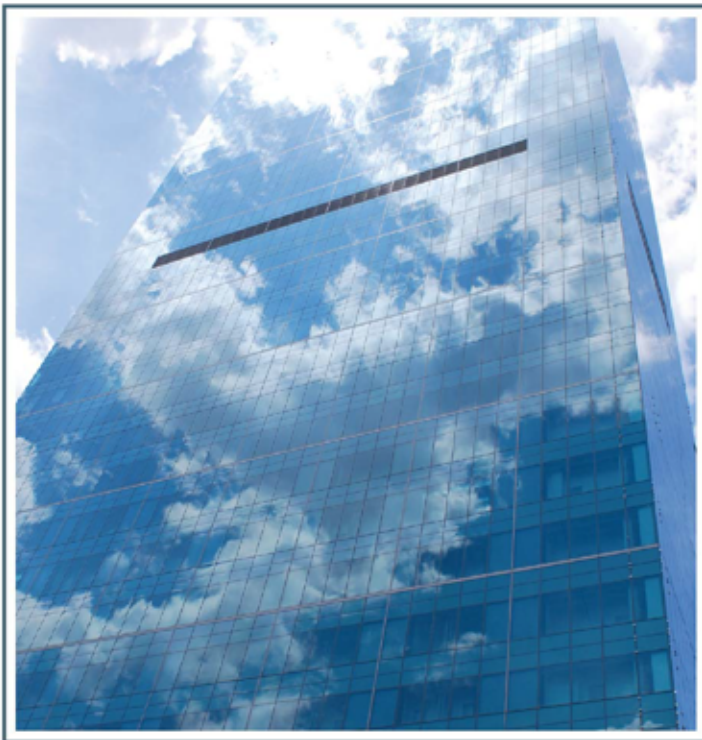

**MẶT DỰNG HỆ 140, ĐỘ DÀY TRUNG BÌNH 2.5 mm**  
*CURTAIN WALL 140, AVERAGE THICKNESS 2.5 mm*

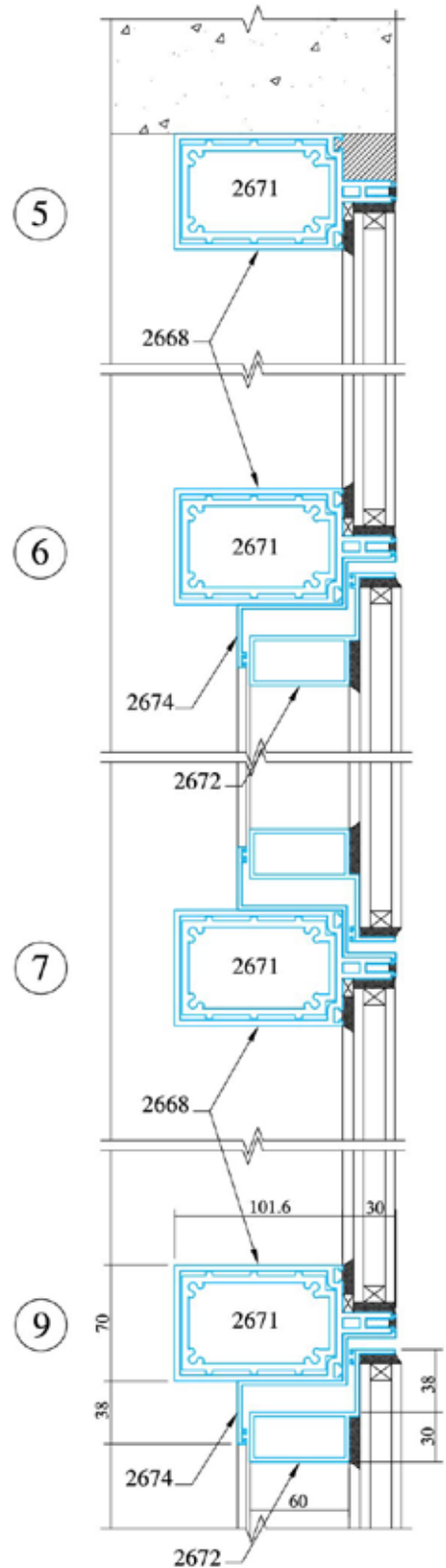
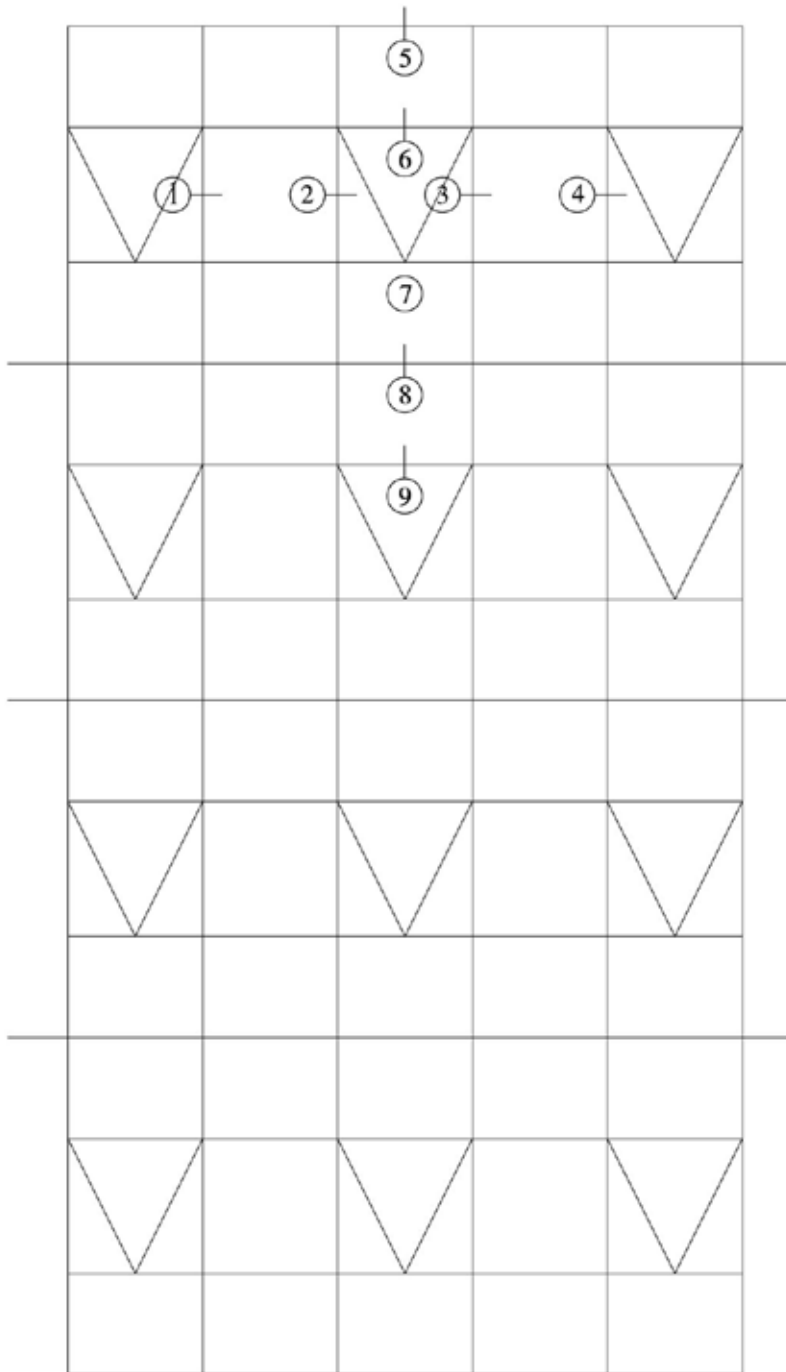

**MẶT DỰNG HỆ 140, ĐỘ DÀY TRUNG BÌNH 2.5 mm**  
*CURTAIN WALL 140, AVERAGE THICKNESS 2.5 mm*

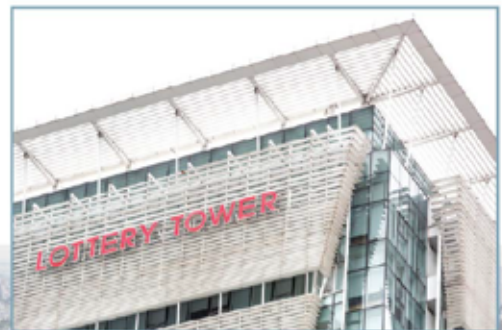
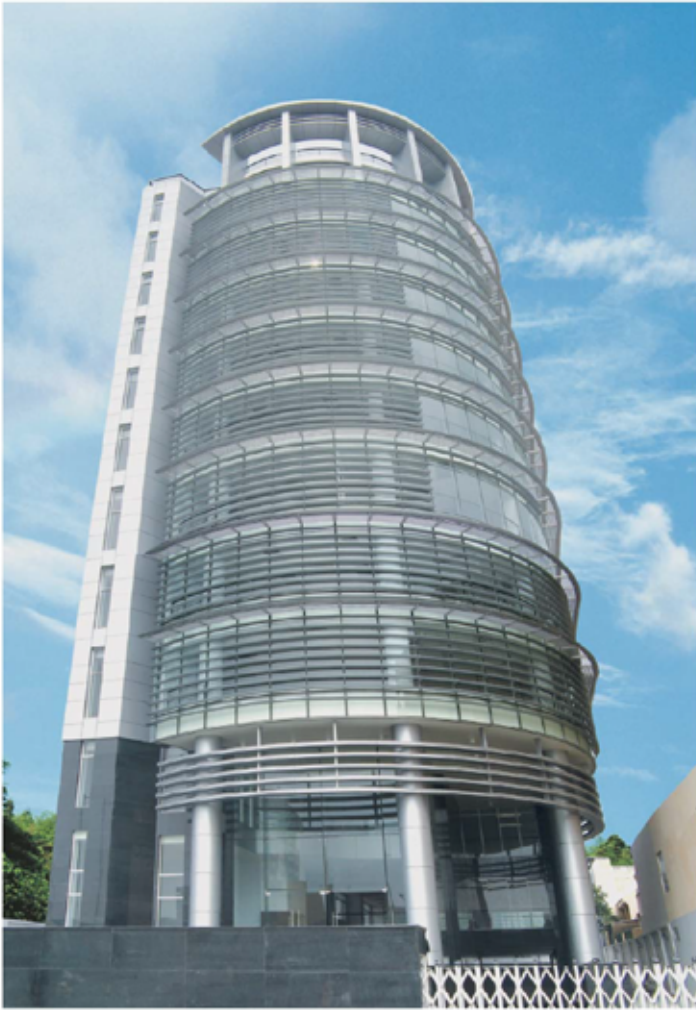

**MẶT DỰNG HỆ 140, ĐỘ DÀY TRUNG BÌNH 2.5 mm**  
*CURTAIN WALL 140, AVERAGE THICKNESS 2.5 mm*

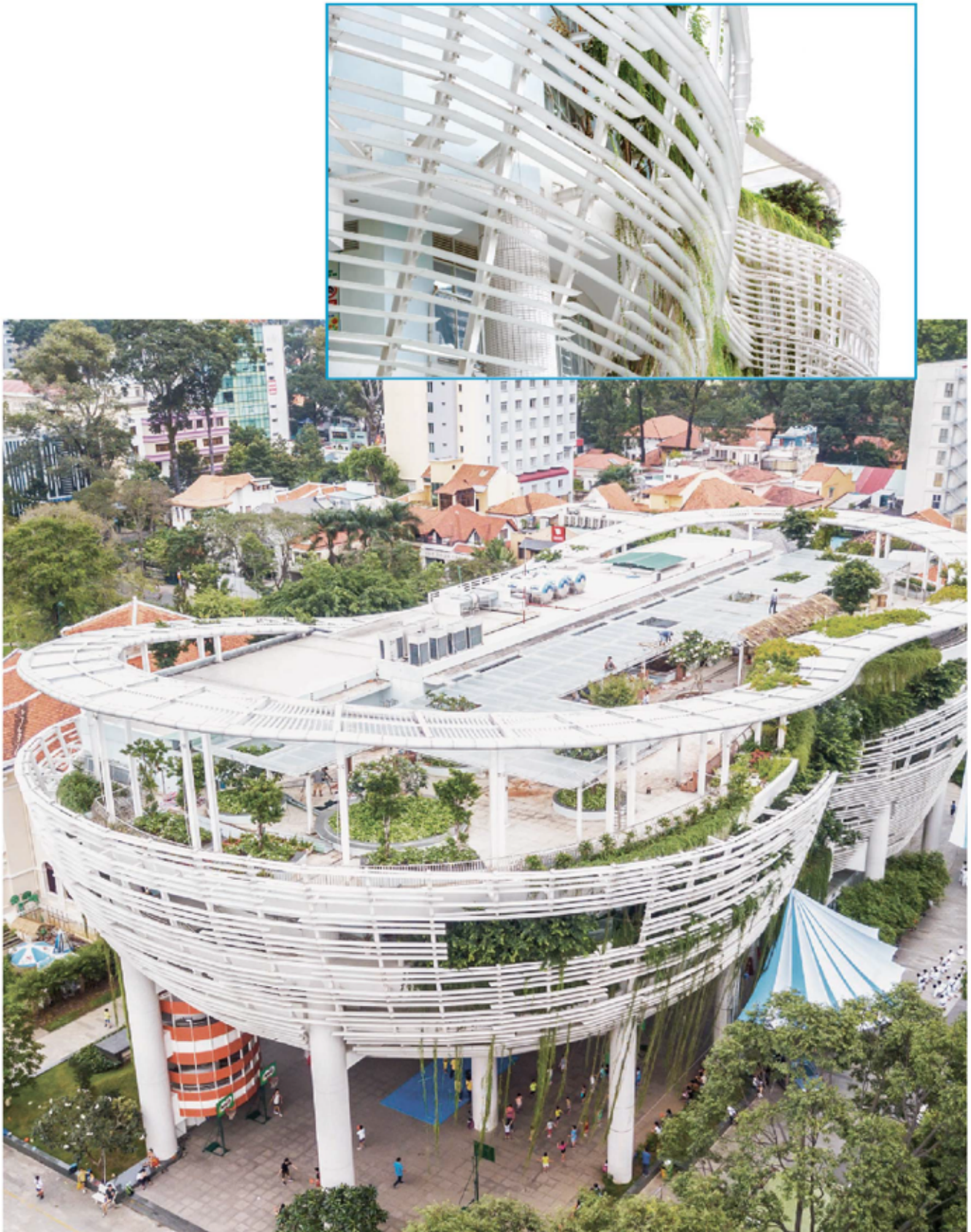

**SAPA BEN THANH ALUMINIUM PROFILES CO., LTD.**

**Add:** Lot C, Street No. 3, Binh Chieu IP, Tam Binh Ward, Ho Chi Minh City, Vietnam

**Tel:** (028) 3896 8780

**Email:** [contact@sapabtg.com](mailto:contact@sapabtg.com) - **Website:** [www.sapabtg.com](http://www.sapabtg.com)